

# Υλοποίηση Software για Timer και Debugging

## Εισαγωγή

Το παρών εργαστήριο σας καθοδηγεί στη διαδικασία εγγραφής μιας βασικής software εφαρμογής που αξιοποιεί τον private timer της CPU. Θα ανατρέχετε στο API του timer στο SDK για να δημιουργήσετε και να κάνετε debug τη software εφαρμογή. Η εφαρμογή που θα αναπτύξετε θα παρακολουθεί τις τιμές του διακόπτη DIP και αυξάνει έναν καταμέτρηση των LED. Η εφαρμογή θα τερματίσει όταν πατηθεί το κεντρικό κουμπί.

## Στόχοι

Μετά την ολοκλήρωση αυτού του εργαστηρίου, θα είστε σε θέση να:

- Αξιοποιήσετε τον private timer της CPU σε polled mode
- Χρησιμοποιήσετε τον SDK Debugger ώστε να καθορίσετε break points και να βλέπετε το περιεχόμενο των μεταβλητών και της μνήμης

## Διαδικασία

Το συγκεκριμένο εργαστήριο χωρίζεται σε βήματα που αποτελούνται από μια γενική επισκόπηση καταστάσεων οι οποίες παρέχουν πληροφορίες σχετικά με τις λεπτομερείς οδηγίες που ακολουθούν. Ακολουθήστε αυτές τις λεπτομερείς οδηγίες για την πρόοδο μέσα στο εργαστήριο.

Το παρόν εργαστήριο περιλαμβάνει 4 πρωταρχικά βήματα: Ανοίξτε το project στο Vivado, δημιουργήστε ένα software project στο SDK, επαληθεύστε τη λειτουργία στο hardware, εκκινήστε τον debugger και κάντε debug το design.

## Περιγραφή Design

Θα χρησιμοποιήσετε το the hardware design που δημιουργήσατε στο lab 4 ώστε να χρησιμοποιήσετε τον private timer της CPU (βλέπε **Figure 1**). Θα αναπτύξετε τον κώδικα για να τον χρησιμοποιήσετε.

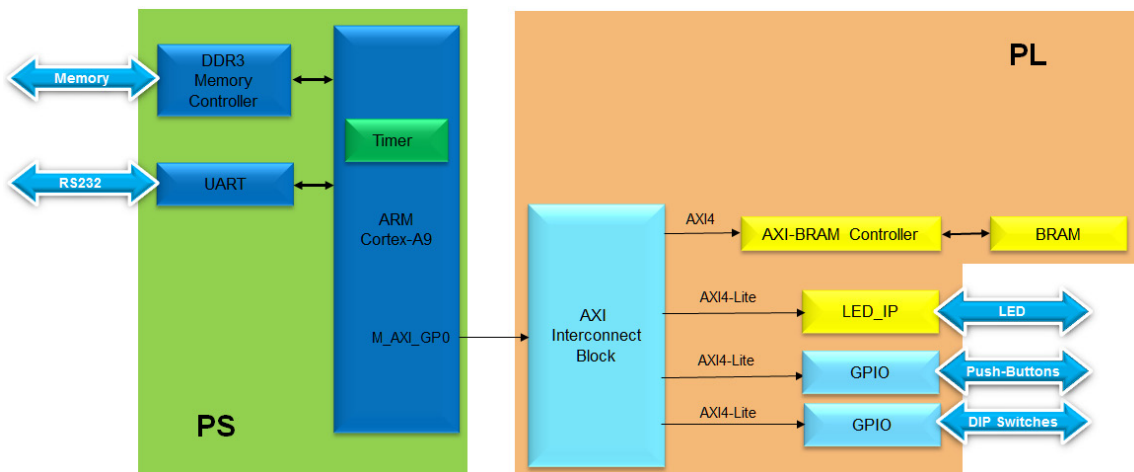
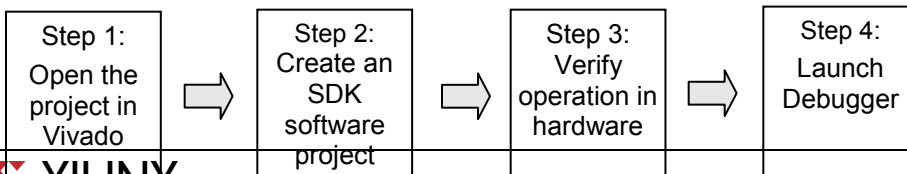

Figure 1. Design updated from Previous Lab

## Γενική Ροή για το παρόν Εργαστήριο



---

In the instructions below;

**{sources}** refers to: C:\xup\embedded\2015\_2\_zynq\_sources

**{labs}** refers to : C:\xup\embedded\2015\_2\_zynq\_labs

**{labsolutions}** for the ZedBoard refers to: C:\xup\embedded\2015\_2\_zedboard\_labsolution  
or for the Zybo refers to: C:\xup\embedded\2015\_2\_zybo\_labsolution

---

## Open the Project in Vivado

## Step 1

1-1. **Use the lab4 project from the last lab or, use the *lab4* from the **{labsolutions}** directory, and save it as *lab5*. Open the project in Vivado and then export to SDK.**

1-1-1. If you wish to continue using the design that you created in the previous lab, open the lab4 project from the previous lab, or open the lab4 project in the **{labsolutions}** directory, and *Save it as* lab5 to the **{labs}** directory

Since we will be using the private timer of the CPU, which is always present, we don't need to modify the hardware design.

1-1-2. Open the Block Design. You may notice that the status changes to synthesis and implementation out-of-date as the project was *saved as*. Since the bitstream is already generated and will be in the exported directory, we can safely ignore any warning about this.

1-1-3. In Vivado, select **File > Launch SDK**

A warning pop-up window indicating that the design is out of date. Since we have not made any changes, we can ignore this.

1-1-4. Click **Yes**.

---

## Create an SDK Software Project

## Step 2

2-1. **Close previously created projects. Create a new empty application project called *lab5* utilizing already existing standalone\_bsp\_0 software platform. Import the *lab5.c* source file.**

2-1-1. In the *Project Explorer* in SDK, right click on *lab4*, *lab4\_bsp* and *system\_wrapper\_hw\_platfrom\_2* and select **Close Project**

2-1-2. Select **File > New > Application Project**.

2-1-3. Name the project **lab5**, and for the board Support Package, (Leave *Create New* for the *Board Support Package*) and click **Next**.

- 2-1-4. Select **Empty Application** and click **Finish**.
- 2-1-5. Select **lab5 > src** in the project explorer, right-click, and select **Import**.
- 2-1-6. Expand **General** category and double-click on **File System**.
- 2-1-7. Browse to {sources}\lab5 folder, select **lab5.c** and click **OK**, and then click **Finish**.

You will notice that there are multiple compilation errors. This is expected as the code is incomplete. You will complete the code in this lab.

## 2-2. Refer to the Scutimer API documentation.

- 2-2-1. Open the **system.mss** from lab5\_bsp
- 2-2-2. Click on **Documentation** link corresponding to **scutimer** (*ps7\_scutimer*) peripheral under the *Peripheral Drivers* section to open the documentation in a default browser window.
- 2-2-3. Click on the **Files** link to see available files related to the private timer API.
- 2-2-4. Browse to the source directory, {Xilinx installation}\SDK\2015.2\data\embeddedsw\XilinxProcessorIPLib\drivers\scutimer\_v2\_0\src and open **xscutimer.h** link to see various functions available.

Look at the *XScuTimer\_LookupConfig*( ) and *XScuTimer\_CfgInitialize*( ) API functions which must be called before the timer functionality can be accessed.

Look at various functions available to interact with the timer hardware, including:

#define	<b>XScuTimer_IsExpired</b> (InstancePtr)
#define	<b>XScuTimer_RestartTimer</b> (InstancePtr)
#define	<b>XScuTimer_LoadTimer</b> (InstancePtr, Value)
#define	<b>XScuTimer_GetCounterValue</b> (InstancePtr)
#define	<b>XScuTimer_EnableAutoReload</b> (InstancePtr)
#define	<b>XScuTimer_DisableAutoReload</b> (InstancePtr)
#define	<b>XScuTimer_EnableInterrupt</b> (InstancePtr)
#define	<b>XScuTimer_DisableInterrupt</b> (InstancePtr)
#define	<b>XScuTimer_GetInterruptStatus</b> (InstancePtr)
#define	<b>XScuTimer_ClearInterruptStatus</b> (InstancePtr)
<b>XScuTimer_Config *</b>	<b>XScuTimer_LookupConfig</b> (u16 DeviceId)
int	<b>XScuTimer_SelfTest</b> ( <b>XScuTimer</b> *InstancePtr)
int	<b>XScuTimer_CfgInitialize</b> ( <b>XScuTimer</b> *InstancePtr, <b>XScuTimer_Config</b> *ConfigPtr, u32 EffectiveAddress)
void	<b>XScuTimer_Start</b> ( <b>XScuTimer</b> *InstancePtr)
void	<b>XScuTimer_Stop</b> ( <b>XScuTimer</b> *InstancePtr)
void	<b>XScuTimer_SetPrescaler</b> ( <b>XScuTimer</b> *InstancePtr, u8 PrescalerValue)
u8	<b>XScuTimer_GetPrescaler</b> ( <b>XScuTimer</b> *InstancePtr)

Figure 2. Useful Functions

## 2-3. Correct the errors

- 2-3-1. In SDK, in the **Problems** tab, double-click on the *unknown type name x* for the parse error. This will open the source file and bring you around to the error place.

```
7 //=====
8 XScuTimer Timer; /* Cortex A9 SCU Private Timer Instance */
9
10 #define ONE_TENTH 32500000 // half of the CPU clock speed/10
11
12 int main (void)
13 {
14
15     XGpio dip, push;
16     int psb_check, dip_check, dip_check_prev, count, Status;
17
18     // PS Timer related definitions
19     XScuTimer_Config *ConfigPtr;
20     XScuTimer *TimerInstancePtr = &Timer;
```

**Figure 3. First error**

- 2-3-2. Add the include statement at the top of the file for the *XScuTimer.h*. Save the file and the errors should disappear.

```
#include "xscutimer.h"
```

- 2-3-3. Scroll down the file and notice that there are few lines intentionally left blank with some guiding comments.

```
31 // Initialize the timer
32
33 // Read dip switch values
34 dip_check_prev = XGpio_DiscreteRead(&dip, 1);
35 // Load timer with delay in multiple of ONE_TENTH
36
37 // Set AutoLoad mode
38
39 // Start the timer
40
```

**Figure 4. Fill in Missing Code**

The timer needs to be initialized, the timer needs to be loaded with the value `ONE_TENTH*dip_check_prev`, AutoLoad needs to be enabled, and the timer needs to be started.

- 2-3-4. Using the API functions list, fill those lines. Save the file and correct errors if any. (Use the completed code further on in this workbook as a guide if necessary.)

Functions needed:     XScuTimer\_LookupConfig( )  
                          XScuTimer\_CfgInitialize( )  
                          XScuTimer\_LoadTimer( )  
                          XScuTimer\_EnableAutoReload( )

---

## XScuTimer\_Start( )

- 2-3-5. Scroll down the file further and notice that there are few more lines intentionally left blank with some guiding comments.

```
if (dip_check != dip_check_prev) {
    xil_printf("DIP Switch Status %x, %x\r\n", dip_check_prev, dip_check);
    dip_check_prev = dip_check;
    // load timer with the new switch settings

    count = 0;
}
if(XScuTimer_IsExpired(TimerInstancePtr)) {
    // clear status bit

    // output the count to LED and increment the count
```

### Figure 5. More Code to be completed

The value of ONE\_TENTH\*dip\_check needs to be written to the timer to update the timer, the InterruptStatus needs to be cleared, and the LED needs to be written to, and the count variable incremented.

Functions needed:     XScuTimer\_LoadTimer( )  
                          XScuTimer\_ClearInterruptStatus ( )  
                          LED\_IP\_mWriteReg ( )

- 2-3-6. Using the API functions list, complete those lines. Save the file and correct errors if necessary.

```

6  #include "XScuTimer.h"
7
8  //=====
9  XScuTimer Timer;      /* Cortex A9 SCU Private Timer Instance */
10
11 #define ONE_TENTH 32500000 // half of the CPU clock speed/10
12
13 int main (void)
14 {
15
16     // Initialize the timer
17     ConfigPtr = XScuTimer_LookupConfig (XPAR_PS7_SCUTIMER_0_DEVICE_ID);
18     Status = XScuTimer_CfgInitialize (TimerInstancePtr, ConfigPtr, ConfigPtr->BaseAddr);
19     if (Status != XST_SUCCESS){
20         xil_printf("Timer init() failed\r\n");
21         return XST_FAILURE;
22     }
23
24     // Read dip switch values
25     dip_check_prev = XGpio_DiscreteRead(&dip, 1);
26
27     // Load timer with delay in multiple of ONE_SECOND
28     XScuTimer_LoadTimer(TimerInstancePtr, ONE_TENTH*dip_check_prev);
29     // Set AutoLoad mode
30     XScuTimer_EnableAutoReload(TimerInstancePtr);
31     // Start the timer
32     XScuTimer_Start (TimerInstancePtr);
33     while (1)
34     {
35
36         if (dip_check != dip_check_prev) {
37             xil_printf("DIP Switch Status %x, %x\r\n", dip_check_prev, dip_check);
38             dip_check_prev = dip_check;
39             // load timer with the new switch settings
40             XScuTimer_LoadTimer(TimerInstancePtr, ONE_TENTH*dip_check);
41             count = 0;
42         }
43         if(XScuTimer_IsExpired(TimerInstancePtr)) {
44             // clear status bit
45             XScuTimer_ClearInterruptStatus(TimerInstancePtr);
46             // output the count to LED and increment the count
47             LED_IP_mWriteReg(XPAR_LED_IP_S_AXI_BASEADDR, 0, count);
48             count++;
49         }
50     }
51     return 0;
52 }

```

Figure 6. Portions of the completed Code

## Verify Operation in Hardware

## Step 3

- 3-1. **Connect the board with micro-usb cable(s) and power it ON. Establish the serial communication using SDK's Terminal tab.**
  - 3-1-1. Make sure that micro-USB cable(s) is(are) connected between the board and the PC. Turn ON the power
  - 3-1-2. Select the  Terminal tab. If it is not visible then select **Window > Show view > Terminal**.

---

3-1-3. Click on  and if required, select appropriate COM port (depends on your computer), and configure it with the parameters as shown. (These settings may have been saved from previous lab).

3-2. **Program the FPGA by selecting Xilinx Tools > Program FPGA and assigning system\_wrapper.bit file. Run the TestApp application and verify the functionality.**

3-2-1. Select **Xilinx Tools > Program FPGA**.

3-2-2. Click the **Program** button to program the FPGA.

3-2-3. Select **lab5** in *Project Explorer*, right-click and select **Run As > Launch on Hardware (GDB)** to download the application, execute ps7\_init, and execute lab5.elf

Depending on the switch settings you will see LEDs implementing a binary counter with corresponding delay.

Flip the DIP switches and verify that the LEDs light with corresponding delay according to the switch settings. Also notice in the Terminal window, the previous and current switch settings are displayed whenever you flip switches.

```
-- Start of the Program --  
DIP Switch Status 1, 3  
DIP Switch Status 3, 7
```

**Figure 7. Terminal window output**

---

## Launch Debugger

## Step 4

4-1. **Launch Debugger and debug**

4-1-1. Right-click on the **Lab5** project in the Project Explorer view and select **Debug As > Launch on Hardware (GDB)**.

The lab5.elf file will be downloaded and if prompted, click **Yes** to stop the current execution of the program.

4-1-2. Click **Yes** if prompted to change to the *Debug perspective*.

At this point you could have added global variables by right clicking in the **Variables** tab and selecting **Add Global Variables ...** All global variables would have been displayed and you could have selected desired variables. Since we do not have any global variables, we won't do it.

4-1-3. Double-click in the left margin to set a breakpoint on various lines in **lab5.c** shown below. A breakpoint has been set when a "tick" and blue circle appear in the left margin beside the line when the breakpoint was set. (The line numbers may be slightly different in your file.)

The first breakpoint is where count is initialized to 0. The second breakpoint is to catch if the timer initialization fails. The third breakpoint is when the program is about to read the dip switch settings. The fourth breakpoint is when the program is about to terminate due to pressing of center push button. The fifth breakpoint is when the timer has expired and about to write to LED.

```

28 XGpio_Initialize(&push, XPAR_BTNS_4BIT_DEVICE_ID);
29 XGpio_SetDataDirection(&push, 1, 0xffffffff);
30
31 count = 0;
32
33 // Initialize the timer
34 ConfigPtr = XScuTimer_LookupConfig (XPAR_PS7_SCUTIMER_0_DEVICE_ID);
35 Status = XScuTimer_CfgInitialize (TimerInstancePtr, ConfigPtr, ConfigPtr->BaseAddr);
36 if(Status != XST_SUCCESS){
37     xil_printf("Timer init() failed\r\n");
38     return XST_FAILURE;
39 }
40 // Read dip switch values
41 dip_check_prev = XGpio_DiscreteRead(&dip, 1);
42 // Load timer with delay in multiple of ONE_SECOND
43 XScuTimer_LoadTimer(TimerInstancePtr, ONE_TENTH*dip_check_prev);
44 // Set AutoLoad mode
45 XScuTimer_EnableAutoReload(TimerInstancePtr);
46 // Start the timer
47 XScuTimer_Start (TimerInstancePtr);
48
49 while (1)
50 {
51     // Read push buttons and break the loop if Center button pressed
52     psb_check = XGpio_DiscreteRead(&push, 1);
53     if(psb_check > 0)
54     {
55         xil_printf("Push button pressed: Exiting\r\n");
56         XScuTimer_Stop(TimerInstancePtr);
57         break;
58     }
59     dip_check = XGpio_DiscreteRead(&dip, 1);
60     if (dip_check != dip_check_prev) {
61         xil_printf("DIP Switch Status %x, %x\r\n", dip_check_prev, dip_check);
62         dip_check_prev = dip_check;
63         // load timer with the new switch settings
64         XScuTimer_LoadTimer(TimerInstancePtr, ONE_TENTH*dip_check);
65         count = 0;
66     }
67     if(XScuTimer_IsExpired(TimerInstancePtr)) {
68         // clear status bit
69         XScuTimer_ClearInterruptStatus(TimerInstancePtr);
70         // output the count to LED and increment the count
71         LED_IP_mWriteReg(XPAR_LED_IP_S_AXI_BASEADDR, 0, count);
72         count++;
73     }
74 }

```

Figure 8. Setting breakpoints

- 4-1-4. Click on the **Resume** (  ) button to continue executing the program up until the first breakpoint is reached.

In the Variables tab you will notice that the *count* variable may have value other than 0.

- 4-1-5. Click on the **Step Over** (  ) button or press F6 to execute one statement. As you do step over, you will notice that the **count** variable value changed to 0.

- 4-1-6. Click on the **Resume** button again and you will see that several lines of the code are executed and the execution is suspended at the third breakpoint. The second breakpoint is skipped. This is due to successful timer initialization.
- 4-1-7. Click on the **Step Over** (F6) button to execute one statement. As you do step over, you will notice that the `dip_check_prev` variable value changed to a value depending on the switch settings on your board.
- 4-1-8. Click on the memory tab. If you do not see it, go to **Window > Show View > Memory**.
- 4-1-9. Click the  sign to add a Memory Monitor

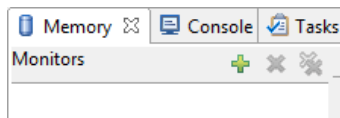

**Figure 9. Monitor memory location**

- 4-1-10. Enter the address for the private counter load register (0xF8F00600), and click **OK**.

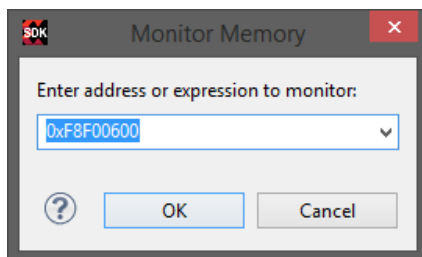

**Figure 10. Monitoring a Memory Address**

You can find the address by looking at the `xparameters.h` file entry to get the base address (`# XPAR_PS7_SCUTIMER_0_BASEADDR`), and find the load offset double-clicking on the `xscutimer.h` in the outline window followed by double-clicking on the `xscutimer_hw.h` and then selecting `XSCUTIMER_LOAD_OFFSET`.

```
# XSCUTIMER_HW_H
# xil_types.h
# xil_io.h
# xil_assert.h
# XSCUTIMER_LOAD_OFFSET
# XSCUTIMER_COUNTER_OFFSET
# XSCUTIMER_CONTROL_OFFSET
# XSCUTIMER_ISR_OFFSET
```

**Figure 11. Memory Offset**

- 4-1-11. Make sure the DIP Switches are not set to "0000" and click on the **Step Over** button to execute one statement which will load the timer register.

Notice that the address `0xF8F00604` has become red colored as the content has changed. Verify that the content is same as the value: `dip_check_prev*32500000`. You will see hexadecimal equivalent (displaying bytes in the order 0 -> 3).

E.g. for `dip_check_prev = 1`; the value is `0x01EFE920`; (reversed: `0x20E9EF01`)

---

4-1-12. Click on the **Resume** button to continue execution of the program. The program will stop at the writing to the LED port (skipping fourth breakpoint as center push button as has not occurred).

Notice that the value of the counter register is changed from the previous one as the timer was started and the countdown had begun.

4-1-13. Click on the **Step Over** button to execute one statement which will write to the LED port and which should turn OFF the LEDs as the count=0.

4-1-14. Double-click on the fifth breakpoint, the one that writes to the LED port, so the program can execute freely.

4-1-15. Click on the **Resume** button to continue execution of the program. This time it will continuously run the program changing LED lit pattern at the switch setting rate.

4-1-16. Flip the switches to change the delay and observe the effect.

4-1-17. Press a push button and observe that the program suspends at the fourth breakpoint. The timer register content as well as the control register (offset 0x08) is red as the counter value had changed and the control register value changed due to timer stop function call. (In the Memory monitor, you may need to right click on the address that is being monitored and click *Reset* to refresh the memory view.)

4-1-18. Terminate the session by clicking on the **Terminate** (  ) button.

4-1-19. Exit the SDK and Vivado.

4-1-20. Power OFF the board.

## Conclusion

This lab led you through developing software that utilized CPU's private timer. You studied the API documentation, used the appropriate function calls and achieved the desired functionality. You verified the functionality in hardware. Additionally, you used the SDK debugger to view the content of variables and memory, and stepped through various part of the code.