

Liquid Crystal Display (LCD) Passive Matrix and Active Matrix Addressing

Introduction

Flat panel displays are now challenging CRT as the display of choice in many applications. Liquid Crystal Displays (LCDs), both passive matrix and active matrix technologies have been developed to replace the once CRT dominated displays market. Passive matrix display costs are lower, but their performance is inferior to active matrix.

This application note examines the two addressing techniques used in current LCDs.

Contents

INTRODUCTION	1
CONTENTS	1
INDEX OF FIGURES	1
INDEX OF TABLES	1
1 PASSIVE MATRIX	2
2 ACTIVE MATRIX.....	3
3 SUMMARY	4

Index of Figures

Figure 1: Passive Matrix Addressing	2
Figure 2: Active Matrix Addressing	3
Figure 3: Active Matrix Thin Film Transistor (TFT).....	4

Index of Tables

Table 1: Liquid Crystal Switching Materials	3
---	---

1 Passive Matrix

Passive matrix displays have rows of electrodes on one half of the display glass and columns of electrodes on the other. The electrodes are usually fabricated out of Indium Tin Oxide (ITO), a semi-transparent metal oxide. When the two pieces of glass are assembled into a display, the intersection of a row and column form a pixel element (*Figure 1*). When a voltage is applied between the two points, the crystal realigns and changes the light transmission properties of the liquid crystal. By repeating this process, scanning through the pixels an image can be formed on the display.

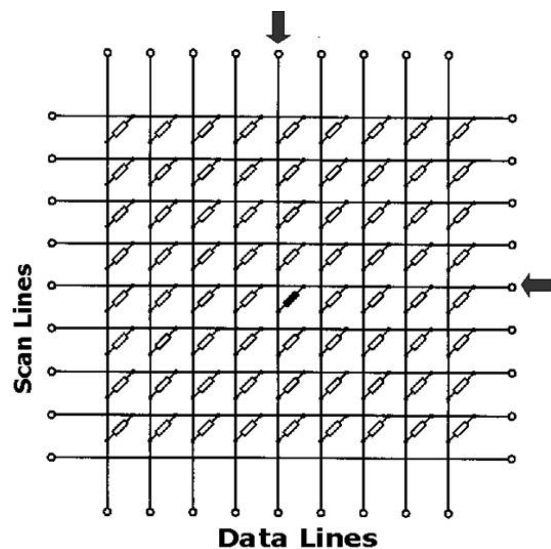

Figure 1: Passive Matrix Addressing

Problems arise as the number of rows and columns increase. With higher pixel density, the electrode size must be reduced and the amount of voltage necessary to drive the display rapidly increases. The higher driving voltage creates a secondary problem; charging effects. Even though only one row and column are selected, the liquid crystal material near the row and column being charged are affected by the pulse. The net result is the pixel selected is active (dark), but the areas surrounding the addressed point are also partially active (greys). The partially active pixels reduce the display contrast and degrade image quality. This effect is known as cross talk.

2 Active Matrix

Passive matrix displays suffer from fundamental problems leading to poor performance. Matrix addressing solves these problems. By placing an electronic switch device in each LC pixel (*Figure 2*), controlling the charging of the LC cell to the desired grey level.

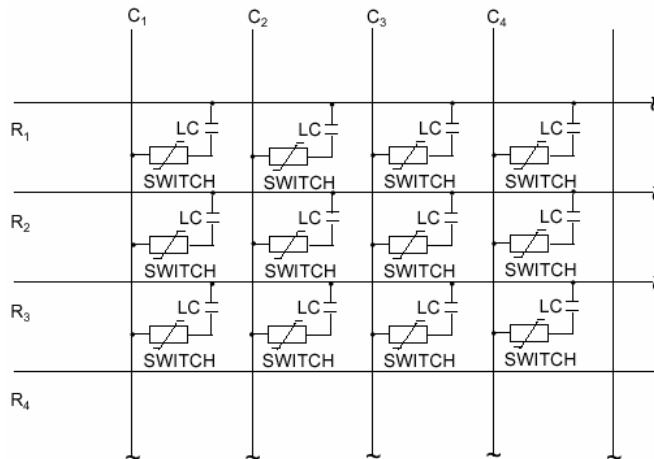

Figure 2: Active Matrix Addressing

There are a number of available technologies which can be used to construct the electronic switches; the materials for which are shown in *Table 1*.

Active elements 2T	Active elements 3T
MIM	a-Si:H TFT
a-Si:H diode	p-Si TFT
	c-Si (SOI)
	CdSe TFT
	MOS (wafer)

Table 1: Liquid Crystal Switching Materials

The active devices can be a-Si:H diodes, ring diodes, or MIM diodes, but more usually (for high resolution displays) thin film transistors. There are a number of transistor technologies, including Cadmium Selenide (CdSe), but the most important are hydrogenated amorphous silicon (a-Si:H) and poly-silicon (p-Si). An active switch is placed in each pixel of a LCD that controls the charging of the LC capacitance to the voltage corresponding to the desired grey level, and storing it there until the next frame refresh. This is done usually by the “one line at a time” method of addressing.

AMLCD (Active Matrix Liquid Crystal Display) technology is more expensive but solves the scanning limitations of passive displays, contrast ratio and grey scale, and the flicker induced by holding signals in pixels in a multiplexed system.

The diagram below (*Figure 3*) shows how thin film transistors are incorporated into a matrix isolating the pixels. The gates are connected together in rows called gate lines or buses, and the data lines are connected to the transistor sources. The liquid crystal, which is sandwiched between two transparent metals (Indium Tin Oxide (ITO)), is represented as a capacitor.

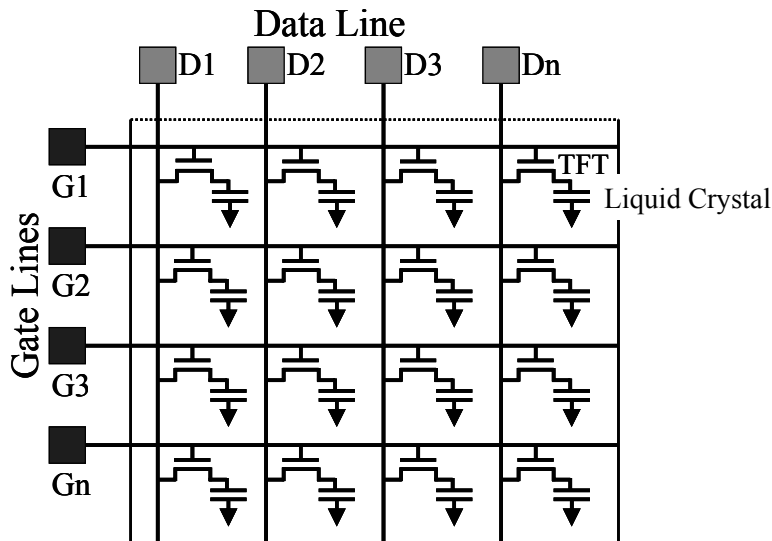

Figure 3: Active Matrix Thin Film Transistor (TFT)

The dominant active matrix technology is thin-film transistors (TFTs) of either a-Si or p-Si. The lower process temperature (<400 degrees centigrade) of a-Si has led to its initial dominance in large-size AMLCD. The present manufacturing of p-Si LCD displays is confined to small-size, usually quartz substrates using high-temperature processes.

3 Summary

Active matrix LCD has been proven to be a superior technology in terms of optical performance; however this comes at a price. Therefore with continued improvement in passive matrix LCD technology and low price compared to AMLCD, passive matrix LCD will continue to be used in many applications and outsell AMLCD for the foreseeable future.

Keep safety first in your circuit designs!

- Hitachi Europe Ltd. puts the maximum effort into making display products better and more reliable, but there is always the possibility that trouble may occur with them. Trouble with display products may lead to personal injury, fire or property damage.
Remember to give due consideration to safety when making your circuit designs, with appropriate measures such as (i) placement of substitutive, auxiliary circuits, (ii) use of nonflammable material or (iii) prevention against any malfunction or mishap.

Notes regarding these materials

- These materials are intended as a reference to assist customers in the selection of the Hitachi Europe Ltd. display products best suited to the customer's application; they do not convey any license under any intellectual property rights, or any other rights, belonging to Hitachi Europe Ltd. or a third party.
- Hitachi Europe Ltd. assumes no responsibility for any damage, or infringement of any third-party's rights, originating in the use of any product data, diagrams, charts, programs, algorithms, or circuit application examples contained in these materials.
- All information contained in these materials, including product data, diagrams, charts, programs and algorithms represents information on products at the time of publication of these materials, and are subject to change by Hitachi Europe Ltd. without notice due to product improvements or other reasons. It is therefore recommended that customers contact Hitachi Europe Ltd. or an authorized Hitachi Europe Ltd. product distributor for the latest product information before purchasing a product listed herein.
The information described here may contain technical inaccuracies or typographical errors.
Hitachi Europe Ltd. assumes no responsibility for any damage, liability, or other loss rising from these inaccuracies or errors.
When using any or all of the information contained in these materials, including product data, diagrams, charts, programs, and algorithms, please be sure to evaluate all information as a total system before making a final decision on the applicability of the information and products. Hitachi Europe Ltd. assumes no responsibility for any damage, liability or other loss resulting from the information contained herein.
- Hitachi Europe Ltd. display products are not designed or manufactured for use in a device or system that is used under circumstances in which human life is potentially at stake. Please contact Hitachi Europe Ltd. or an authorized Hitachi Europe Ltd. product distributor when considering the use of a product contained herein for any specific purposes, such as apparatus or systems for transportation, vehicular, medical, aerospace, nuclear, or undersea repeater use.
- The prior written approval of Hitachi Europe Ltd. is necessary to reprint or reproduce in whole or in part these materials.
- Please contact Hitachi Europe Ltd. for further details on these materials or the products contained therein.

Copyright © Hitachi Europe Ltd. All rights reserved