



Blended Intensive Program (BIP):

“Additive Manufacturing: Design and Processing”

Topology Optimization for Additive Manufacturing

Ioannis Ntintakis
Lecturer

NTop platform

Students, educators, or researchers are able to join the nTopEd community and get access to a non-commercial license of nTopology for free

How to install the Ntop education platform:

<https://ntopology.com/education/>

Implicit Modeling in Ntop

- Implicit modeling is a powerful way to define, change and represent 3D geometry. Geometry is defined through equations in such an approach, rather than through a network of vertices, edges, and faces like meshes and BReps. This means that implicits are significantly lighter to compute and maintain their pure form because they are not discretized like meshes and BReps, which don't always capture continuity perfectly

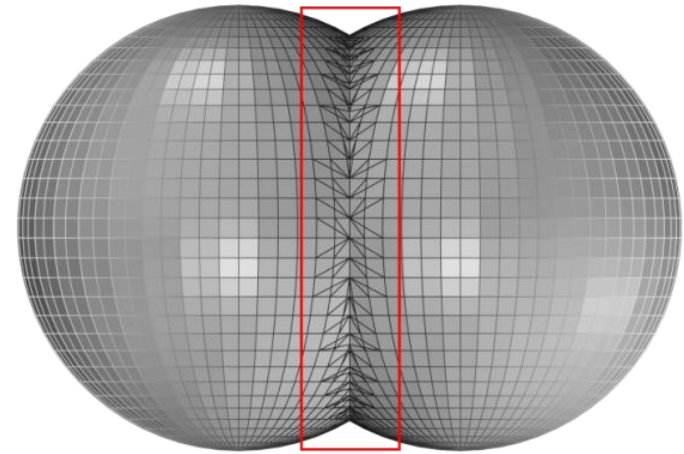

Potential Problem Areas

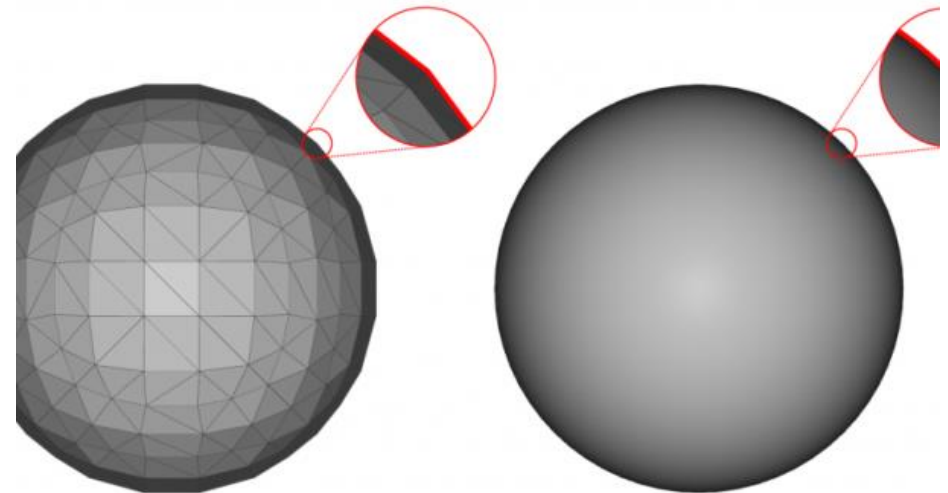

Import Model in NTop from CAD

<u>File Type</u>	<u>File Extension</u>	<u>Versions</u>
ACIS	.sat and .sab	R1 - 2019 1.0
CATIA v5	.CATpart	V5 R8 - V5-6 R2019
PTC Creo	.prt	1.0 - 6.0
Autodesk Inventor	.ipt	V11 - 2019
Siemens NX	.prt	11 - NX1847
Parasolid	.x_t and .x_b	9.0 - 31.1.188
Solidworks	.sldpart	98 - 2019
STEP	.stp and .step	AP 203, AP 214, AP252

Import Model in NTop from CAD

- *Method 1: Drag and Drop*
- With nTop Platform open, open File Explorer and search for your file. Once found, drag and drop it into the main viewport window. This will import your part and automatically create a block.

- *Method 2: File > Import*
- Go up to File > Import (or use hot-key CTRL - i) to open the Import Window. From there, choose your file and it will import your part.

- *Method 3: Import Block*
- Use the search bar (CTRL-L) and type in 'Import'. All of the import options will pop up, allowing you to choose which block you need. These blocks can also be found in the Ribbon.

Initial CAD Model

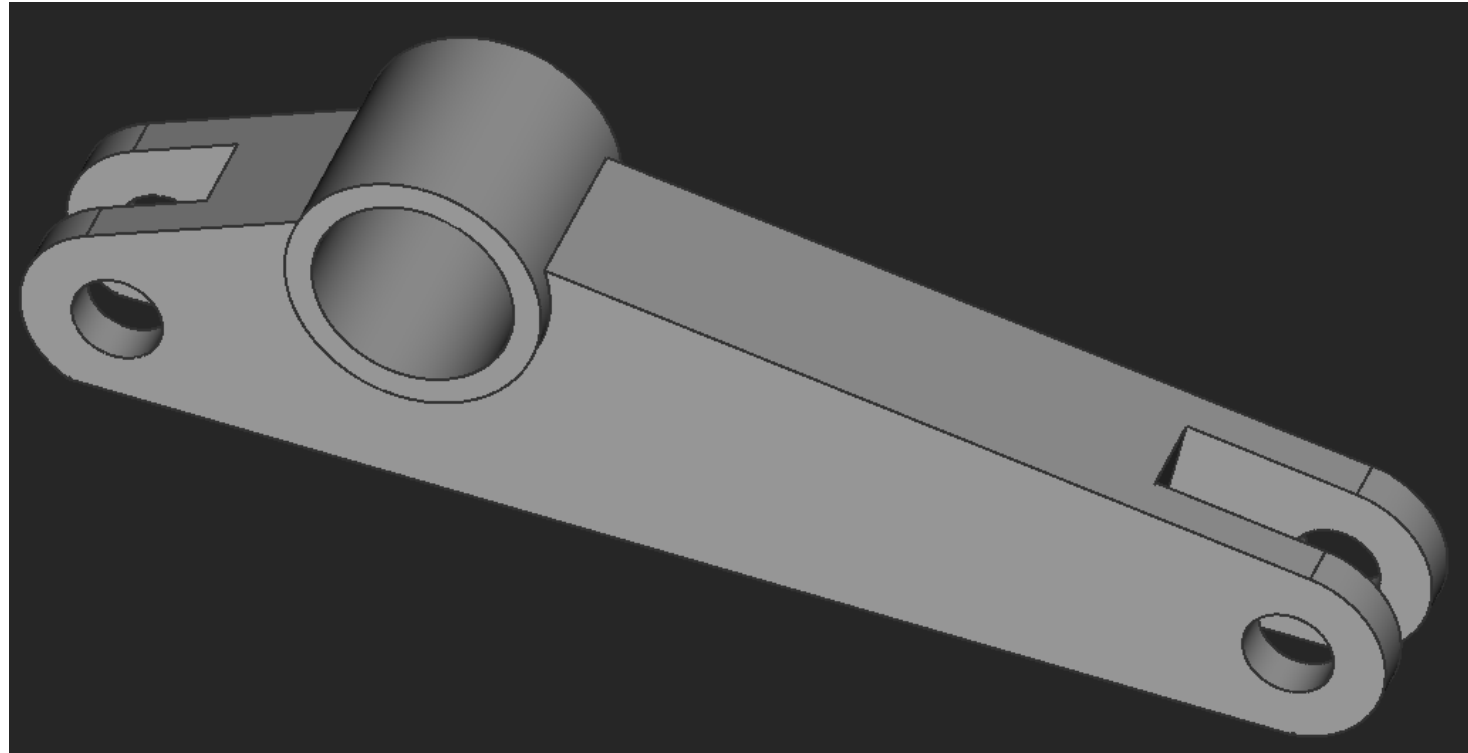

Create a Mesh

Mesh from CAD body block

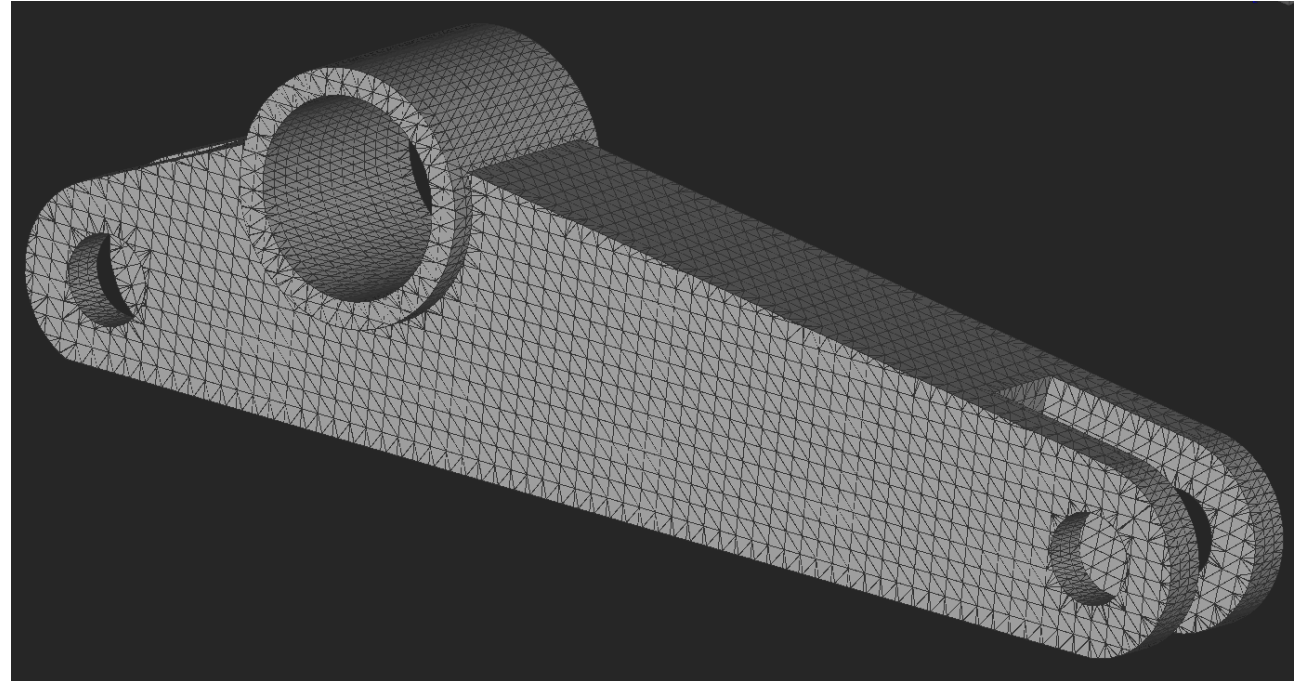
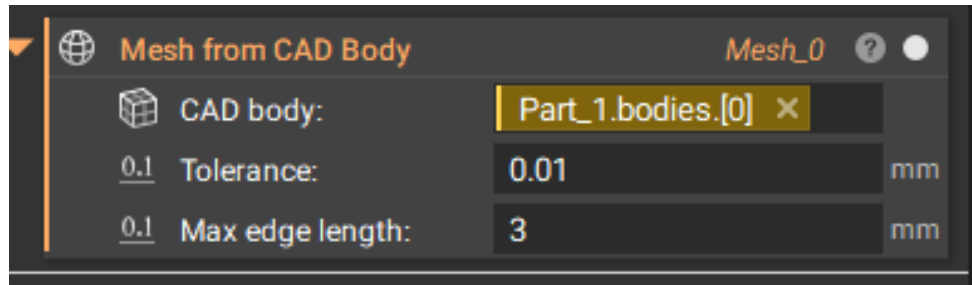
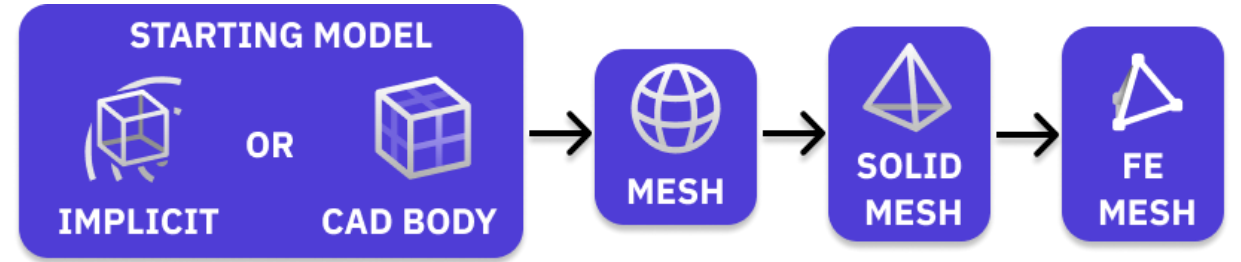

ReMesh the body

ReMesh the body with the use of **Remesh Surface** block, use the previous mesh block as surface

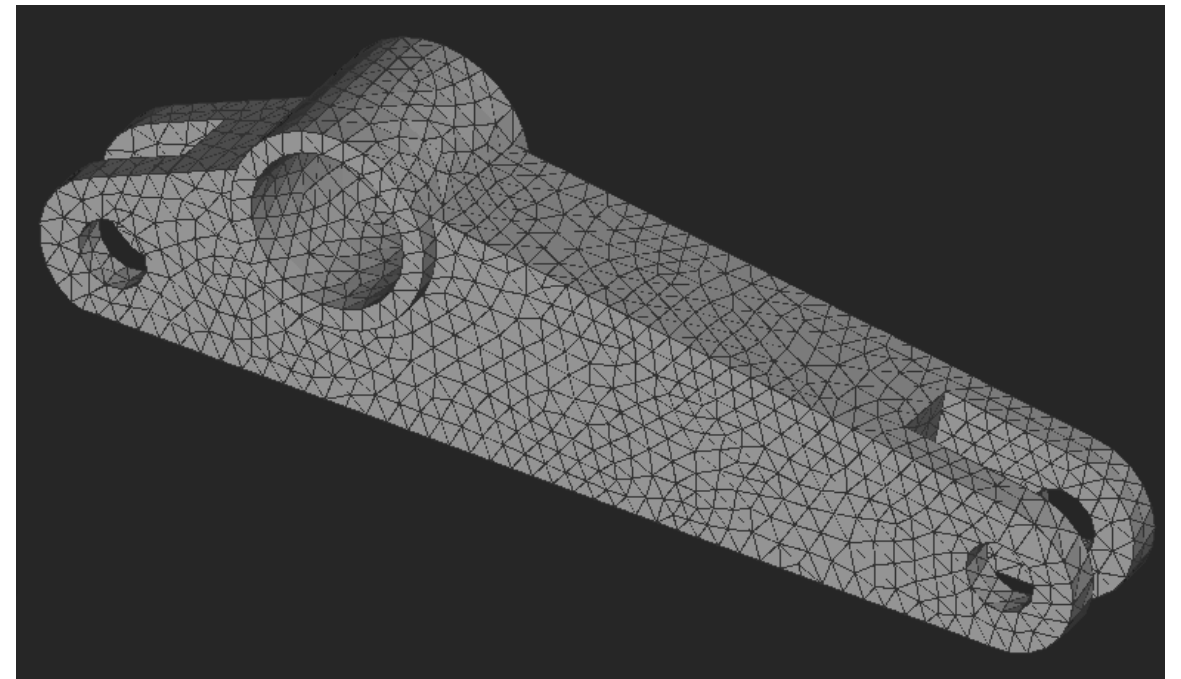
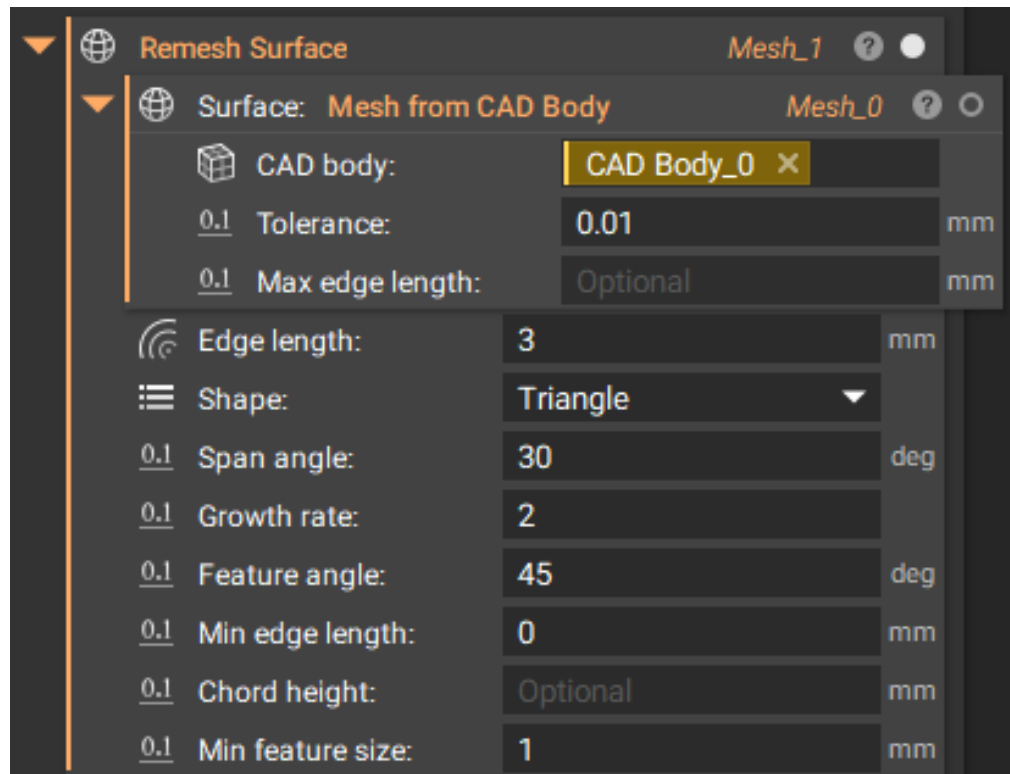

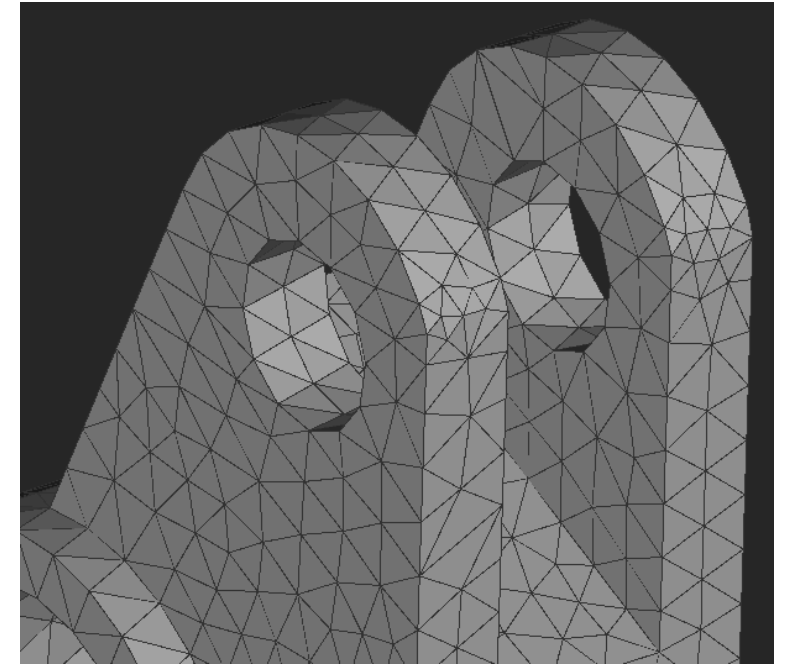
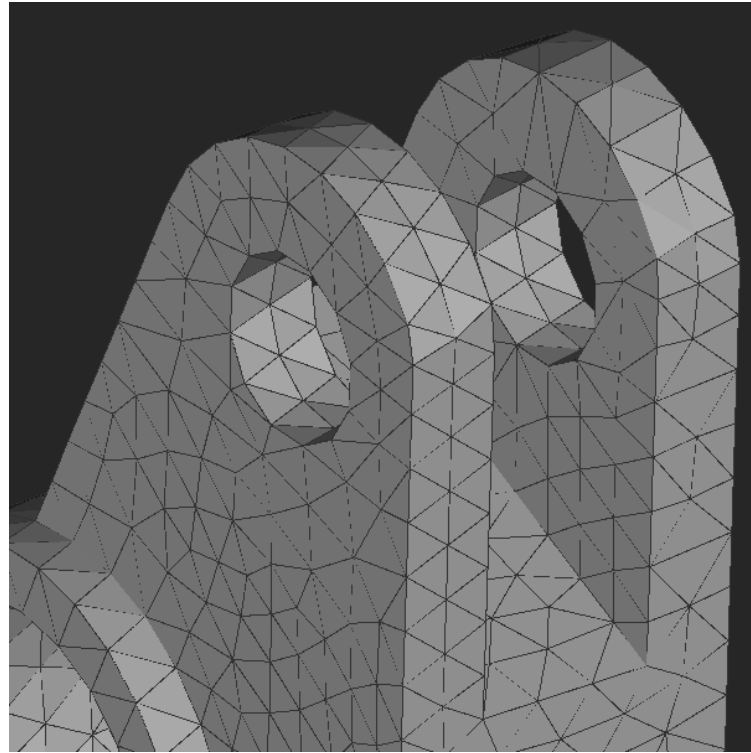
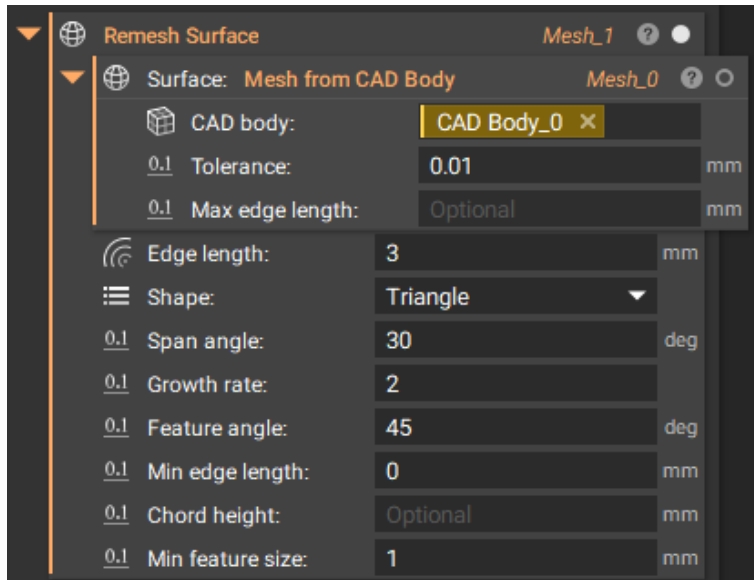

ReMesh the
body

ReMesh the body with the use of **Remesh Surface** block, use the previous mesh block as surface

Volume Mesh

Is the preferred method for simple geometry, as it is speedy but less tolerant of defects. Volume Mesh may also work after taking steps to repair input errors.

Use a **Volume Mesh** block and use the previous remesh surface

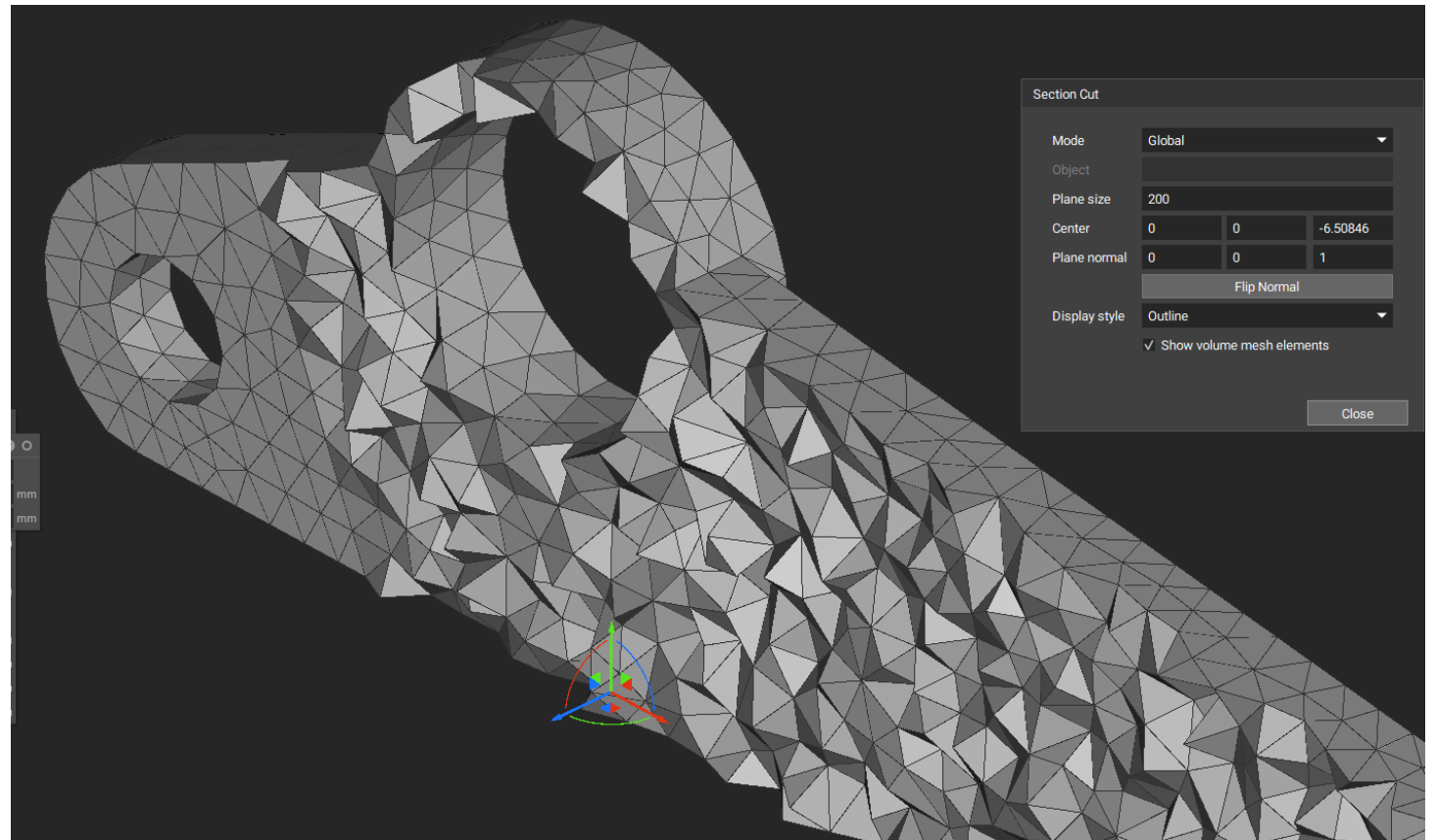
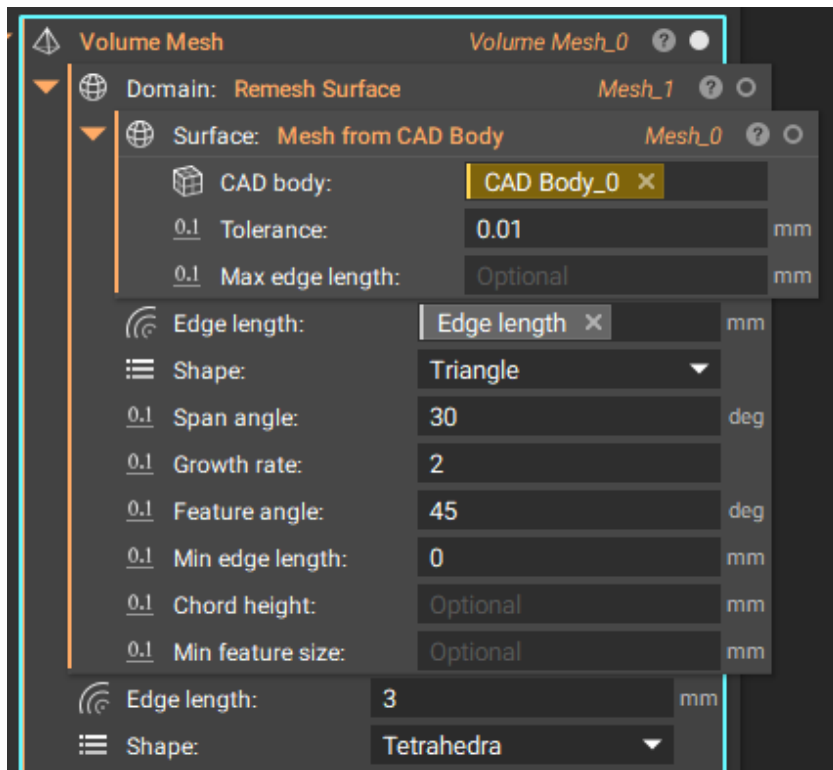

FE Volume Mesh

Convert the Solid Mesh into a Finite Element Mesh by using FE Volume Mesh block, this conversion adds integrations points within the mesh

Use a **FE Volume Mesh** block and use the previous volume Mesh

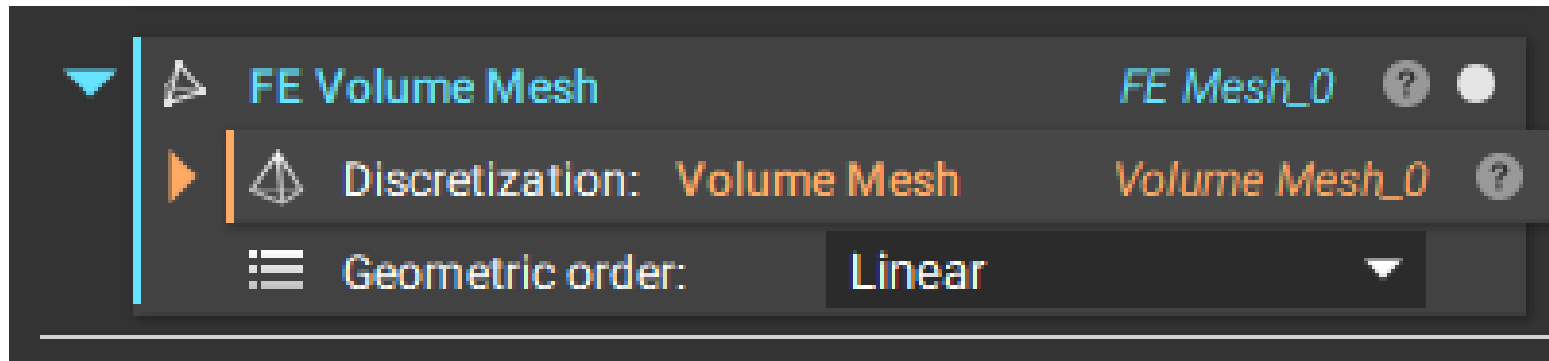

Create a FE Model

An FE model brings together all of the necessary elements for the part to be analyzed, whether in simulation, optimization, or further analysis

The FE Model needs a Material block in order to assign properties to the part

You can choose from the list of Sample Materials or build your own Isotropic or Orthotropic Material

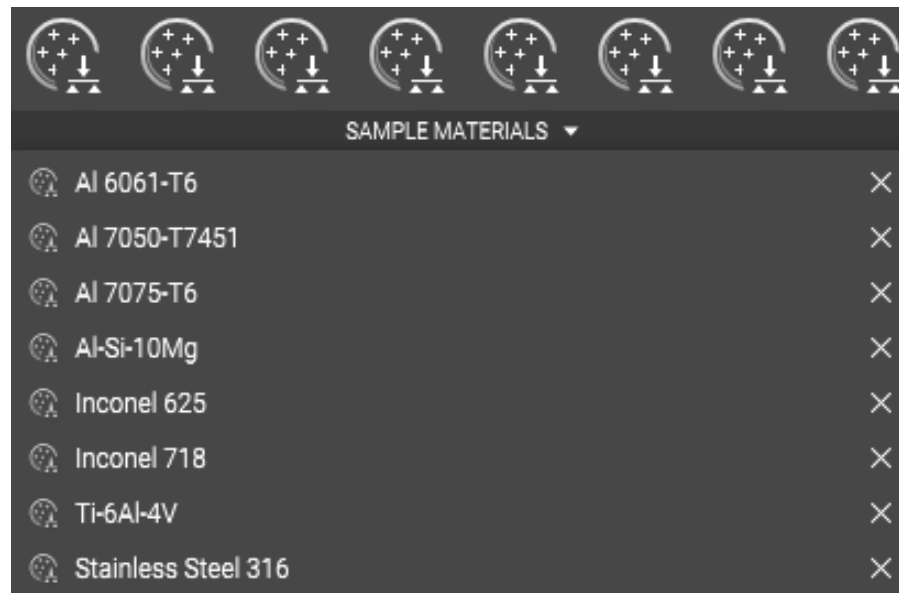

Create a FE Model -Define Material Properties- 1/3

Two materials selection:

Isotropic

Orthotropic

Add an **Isotropic Material** or an **Orthotropic Material** block

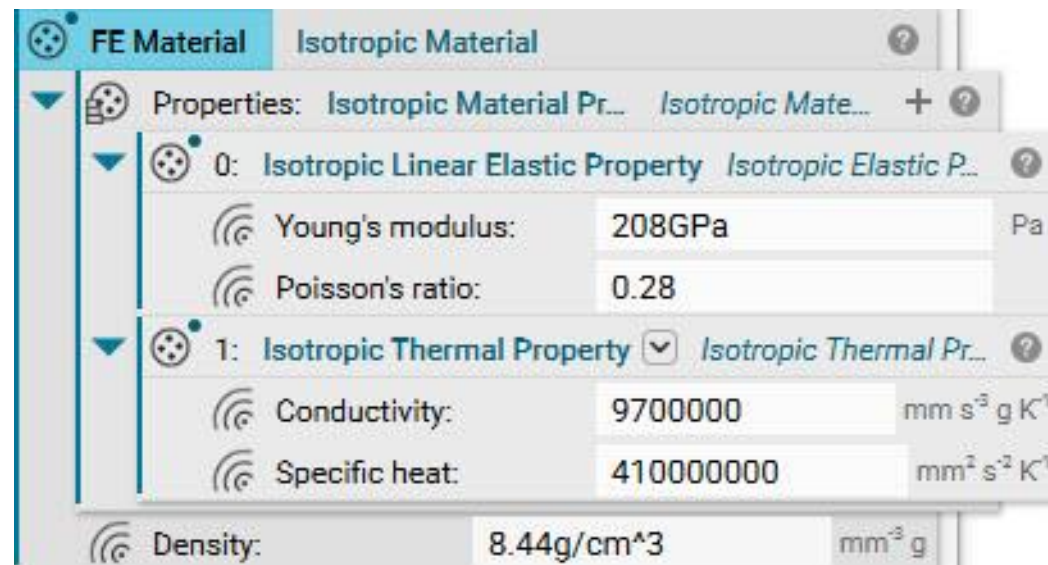

Create a FE Model -Define Material Properties- 2/3

Our Isotropic Material properties are:

a Young's modulus of 2.3×10^{11} Pa and a Poisson's Ratio of 0.32

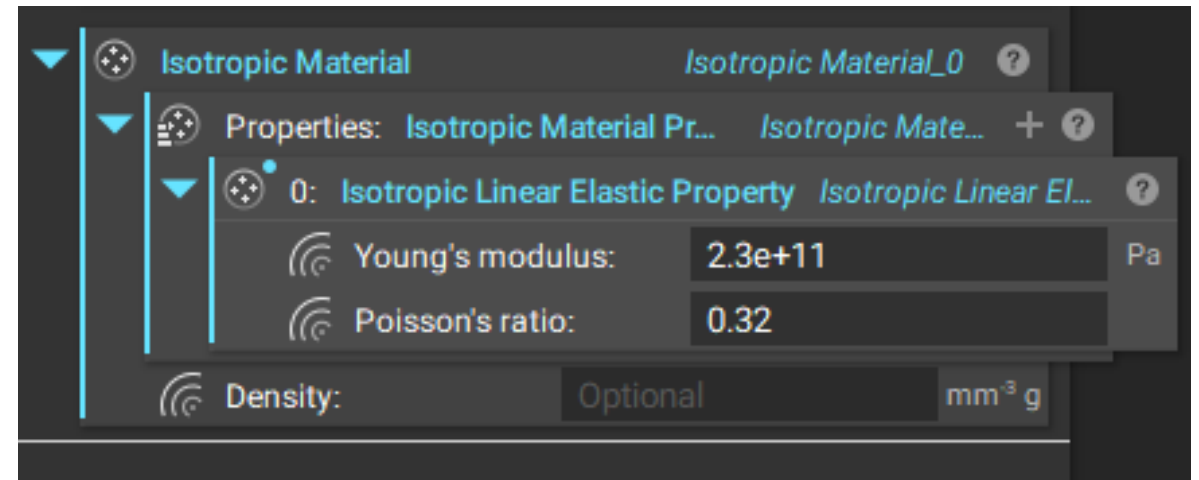
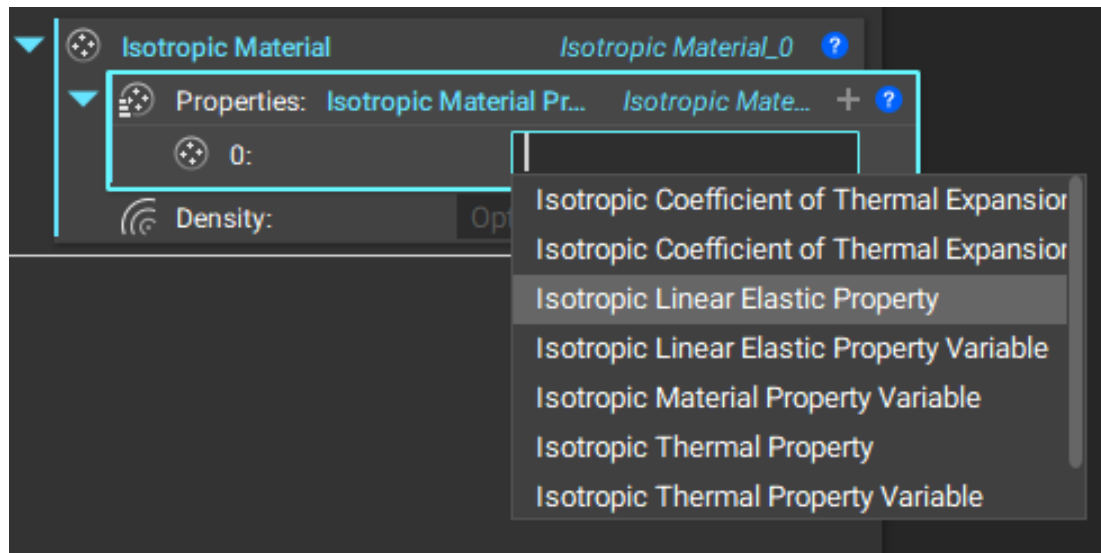

Create a FE Model –FE Component- 3/3

With FE model creation the material properties is going to assigned to the mesh, insert **FE Solid Attribute** block
After this step a FE Solid model will be created

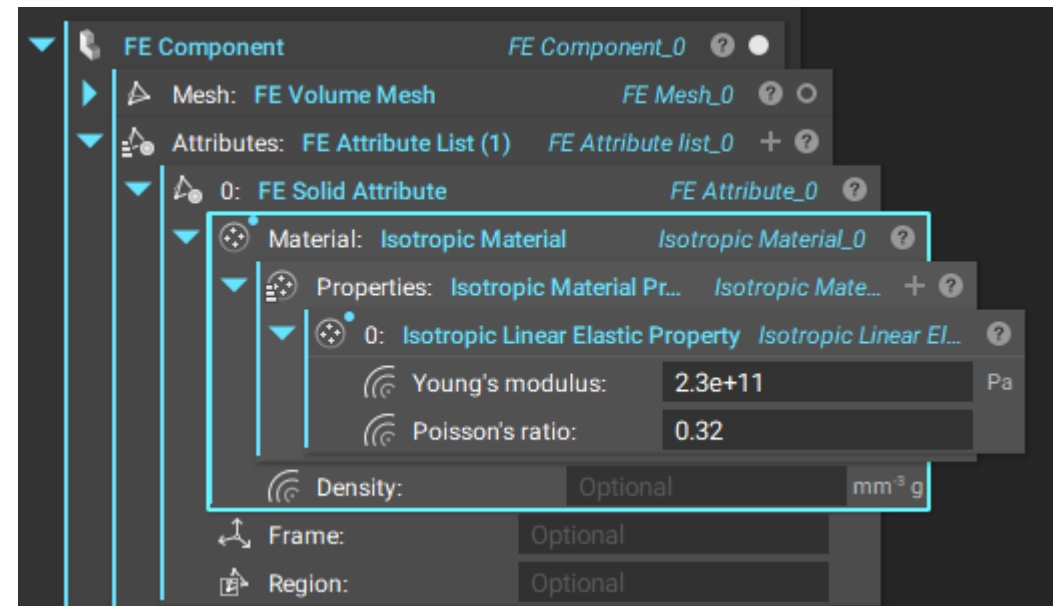
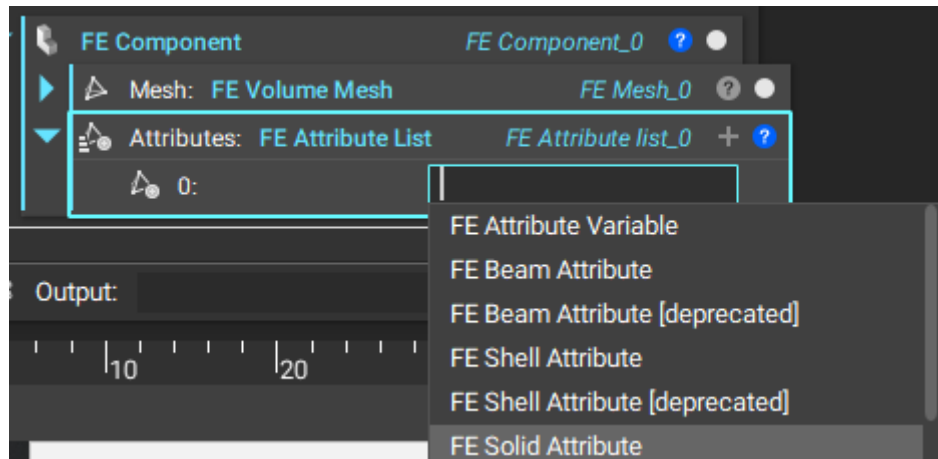

Create a FE Model

With FE model creation we are ready to continue in Boundary Condition definition

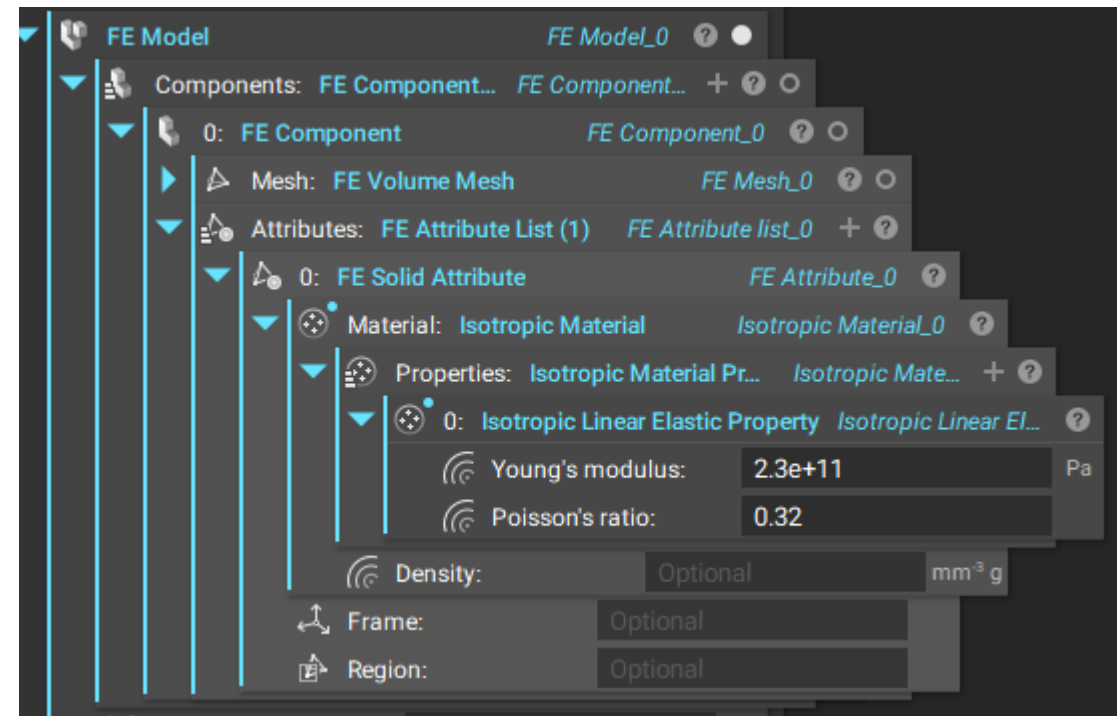
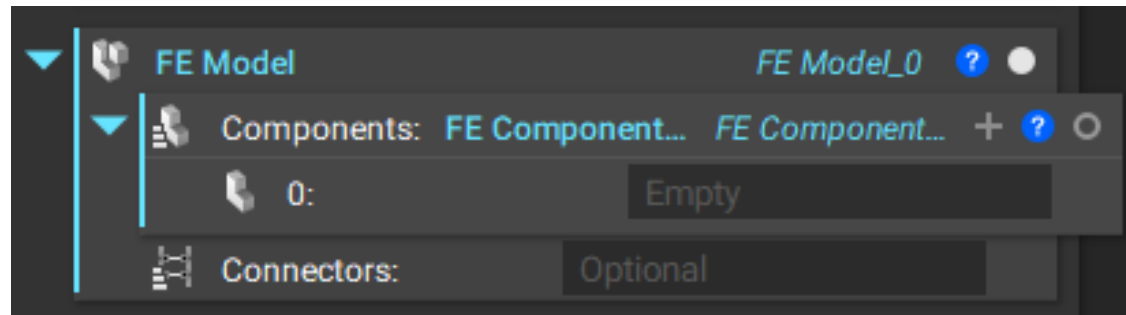

Add Boundary Conditions

Boundary Conditions (BCs) can be thought of as the environment your part is in

They include Forces, Displacement Restraints, Heat Generation, Pressure, and more

All of the internal and external elements acting on your model

You need a minimum of two BCs to run a simulation

Depending on the BC, they are usually made up of a Boundary, a Vector, and a Frame.

Add Boundary Conditions

At the Brake Pedal example, we can identify what BCs we want to use in our Static Analysis. The force is where your foot would be pressing on and the displacement restraint is where the pedal is connected to another piece and fixed in place. A Displacement Restraint is usually required when forces are involved to ensure the part is fixed in space. Without it, the simulation wouldn't be able to run

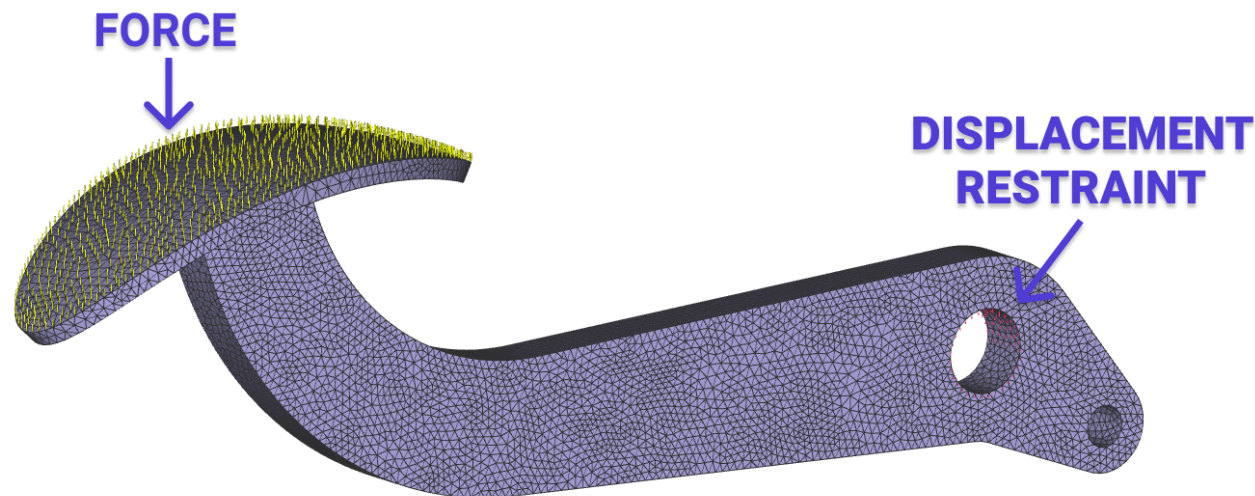

Boundary Conditions – Add Force 1/2

Add a **FE Boundary by body** block to prepare the force location

The FE Boundary by Body block selects entities of an FE Mesh (faces, edges, nodes) within the desired tolerance of an Implicit Body

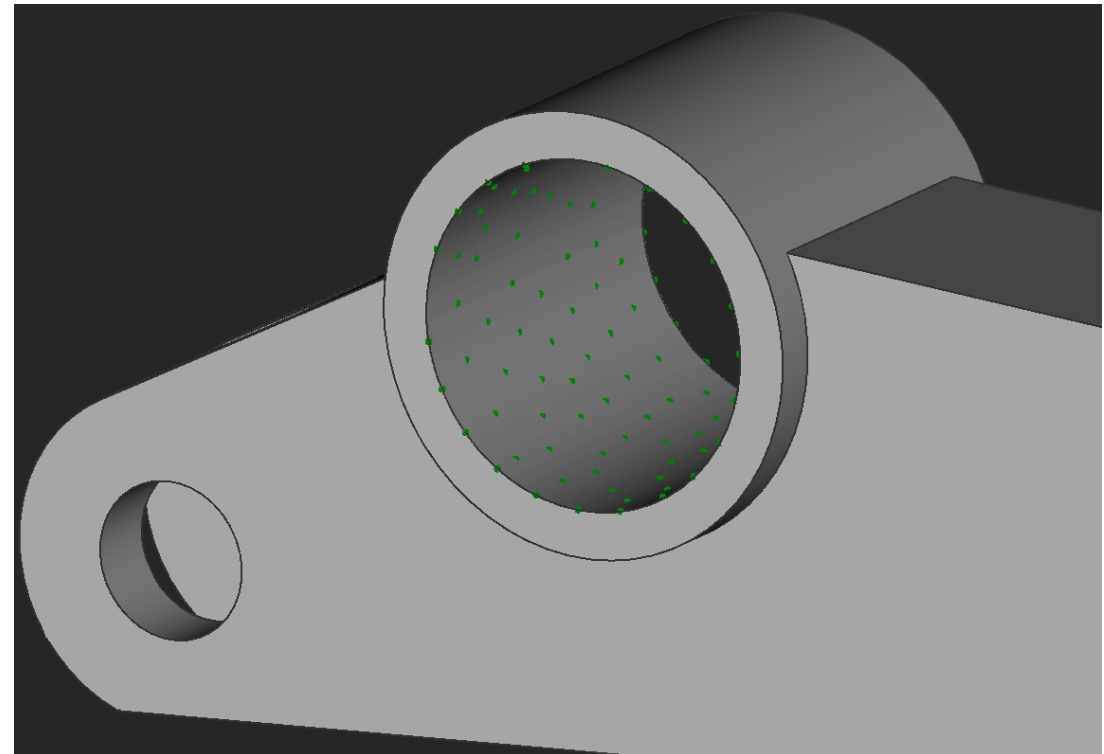
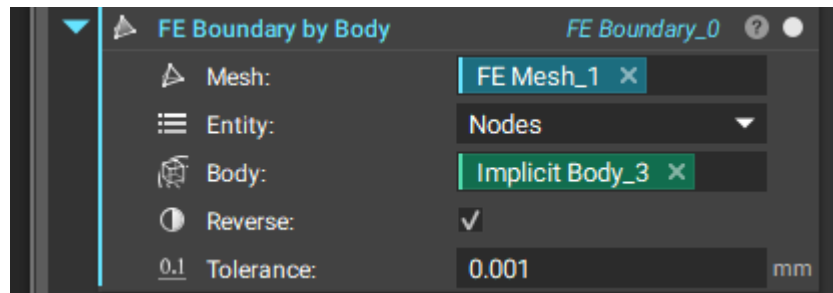
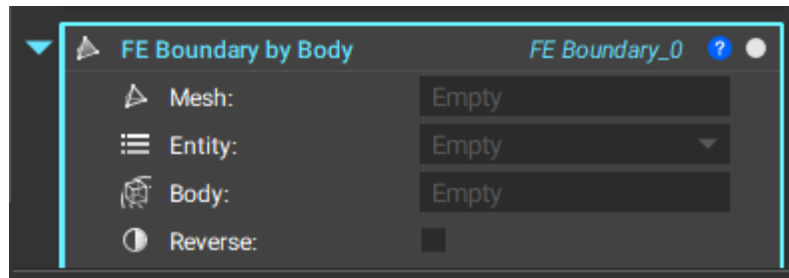

Boundary Conditions – Add Force 2/2

Add a **Force** block

Insert the FE Boundary by body you create before into the Boundary input

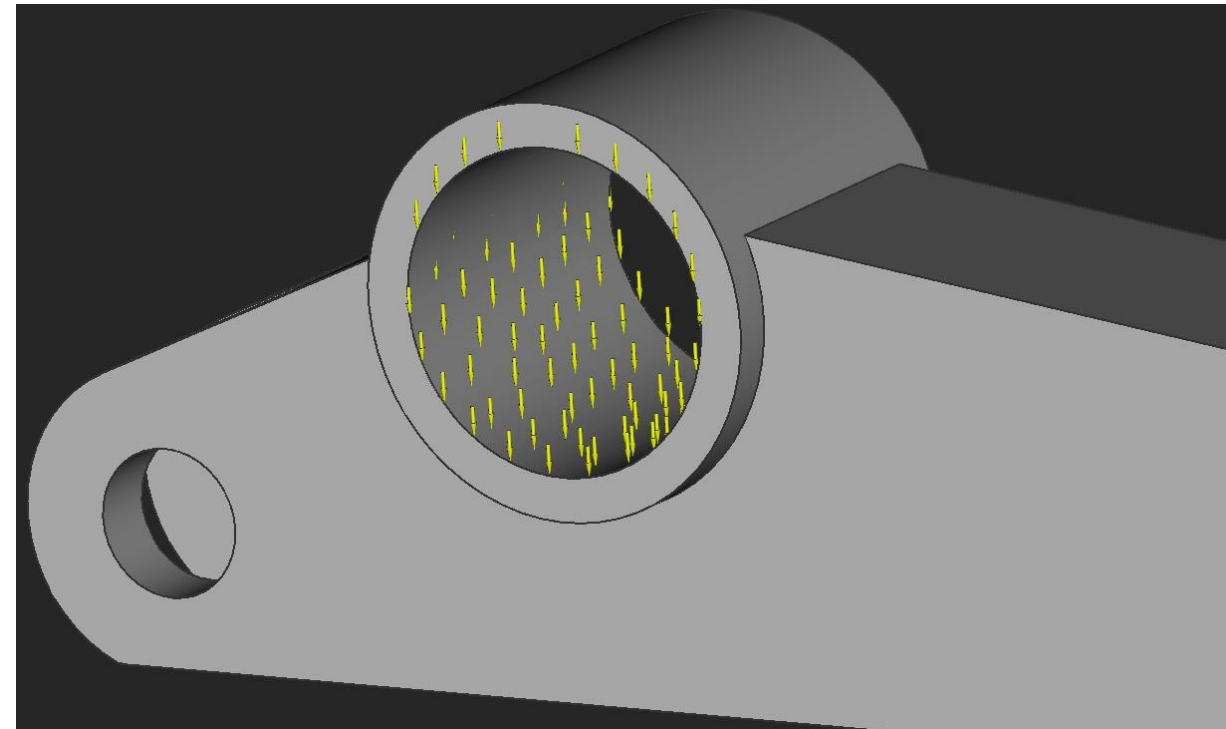
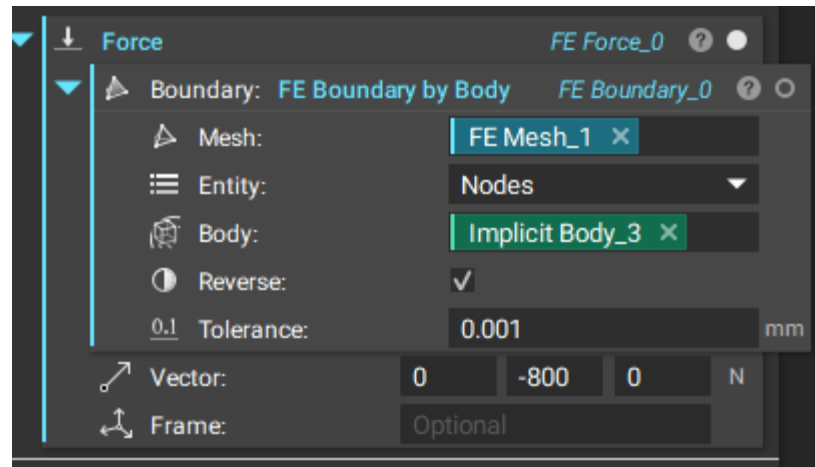
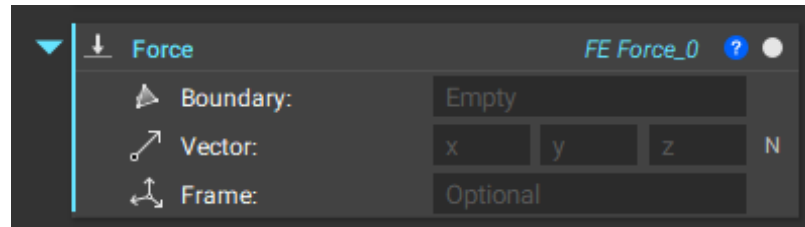

Boundary Conditions – Displacement Restraint 1/3

Add a **FE Face Boundary** block, this allows to select multiple faces from the CAD body

The selected faces from the CAD body must have been already converted to **CAD Face Variable**

In order to convert a face to CAD Face Variable:

1. Select the face
2. Right click on this and select the option Create CAD Face Variable
3. Repeat the above for all appropriate CAD faces

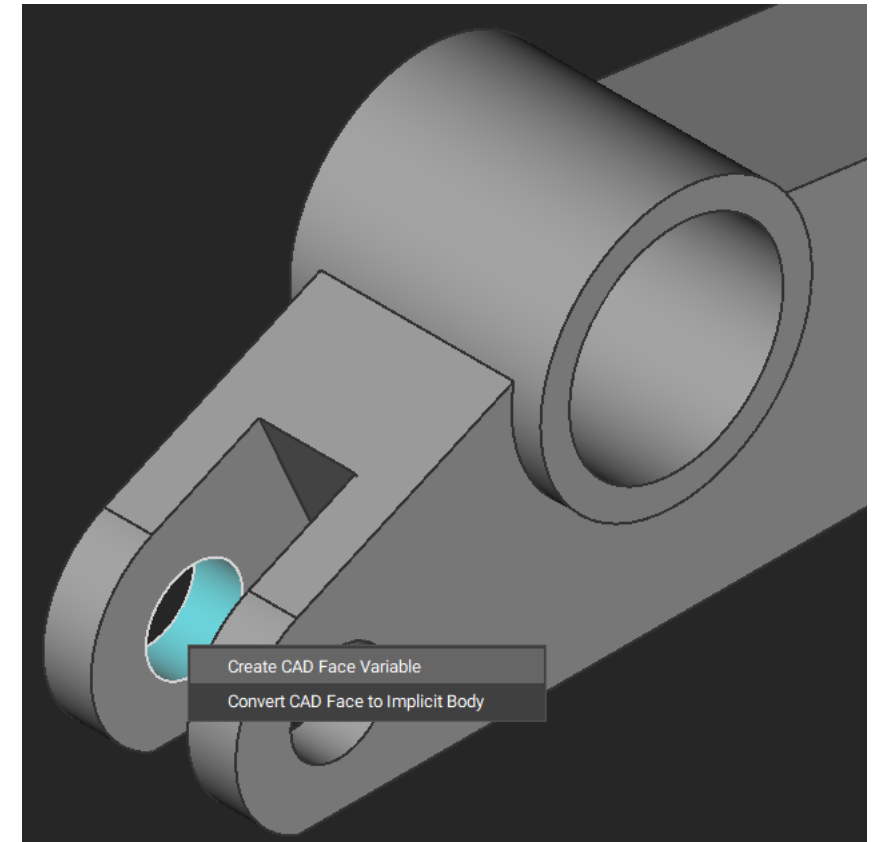

Boundary Conditions – Displacement Restraint 2/3

Add a **FE Face Boundary** block, this allows to select multiple faces from the CAD body

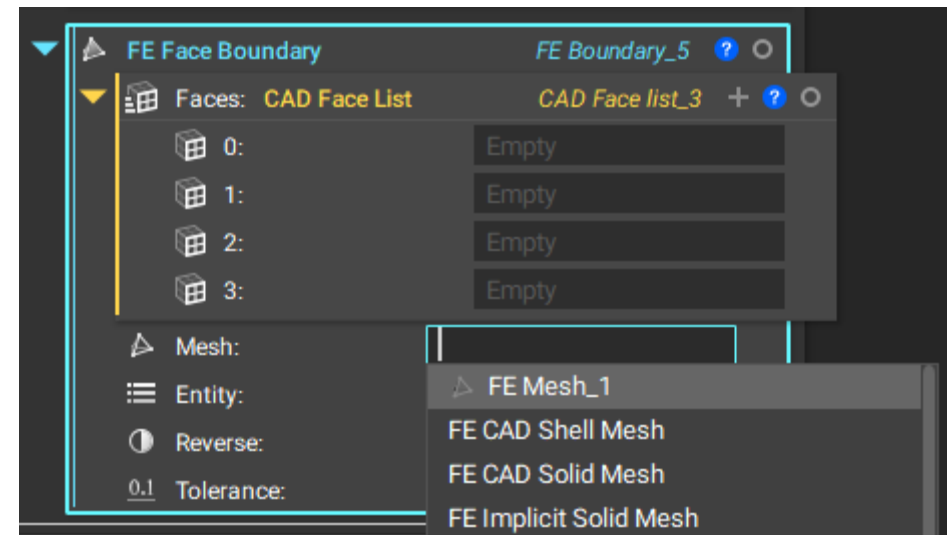
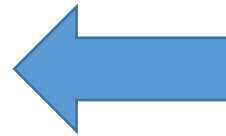
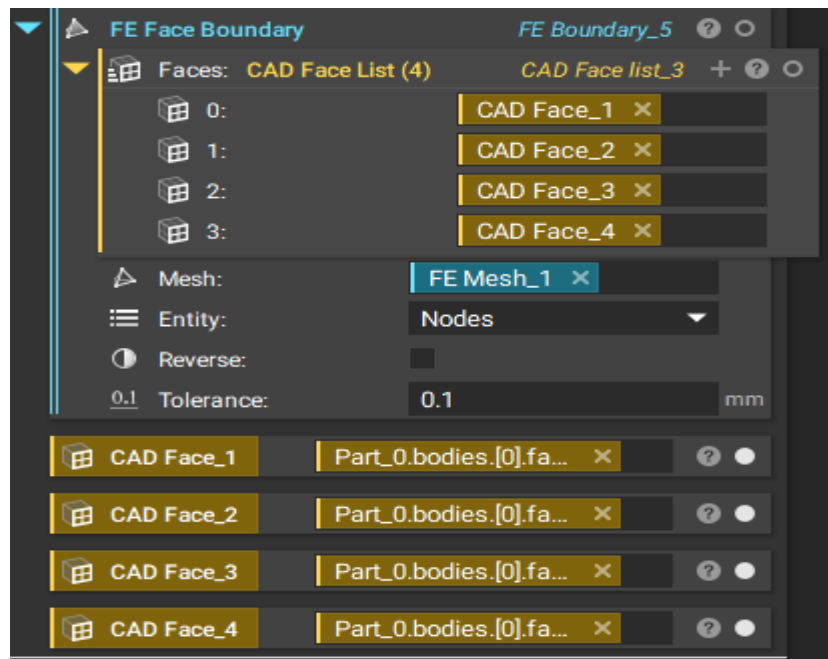
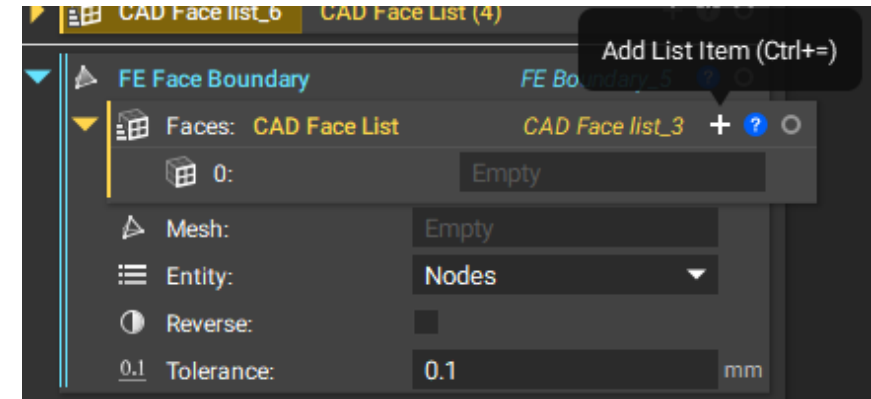
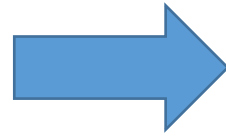
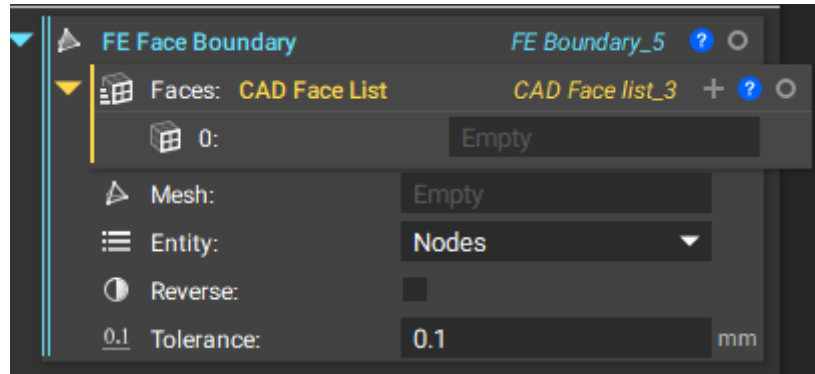

Boundary Conditions – Displacement Restraint 3/3

Add a **Displacement Restraint** block, and insert the FE Boundary block

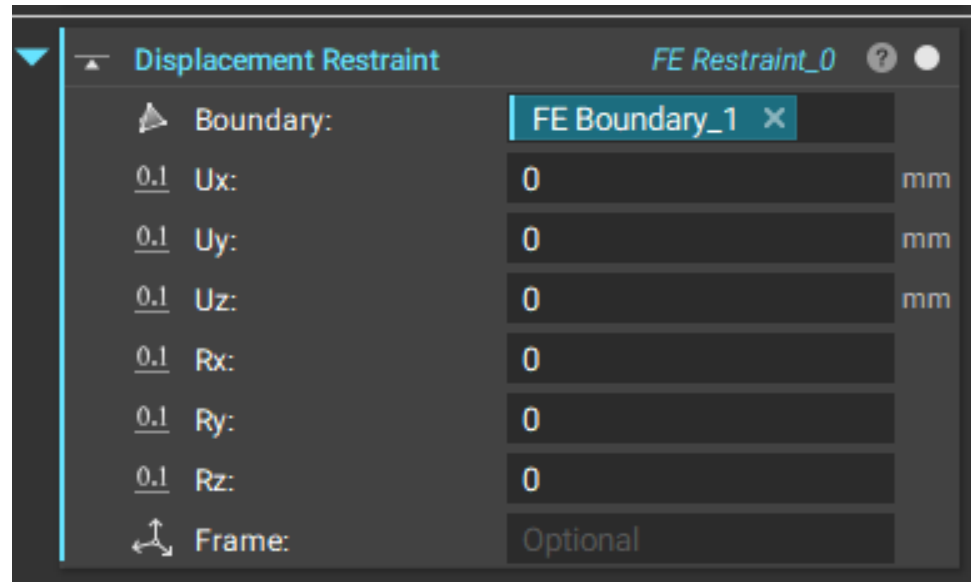

The final FE Model

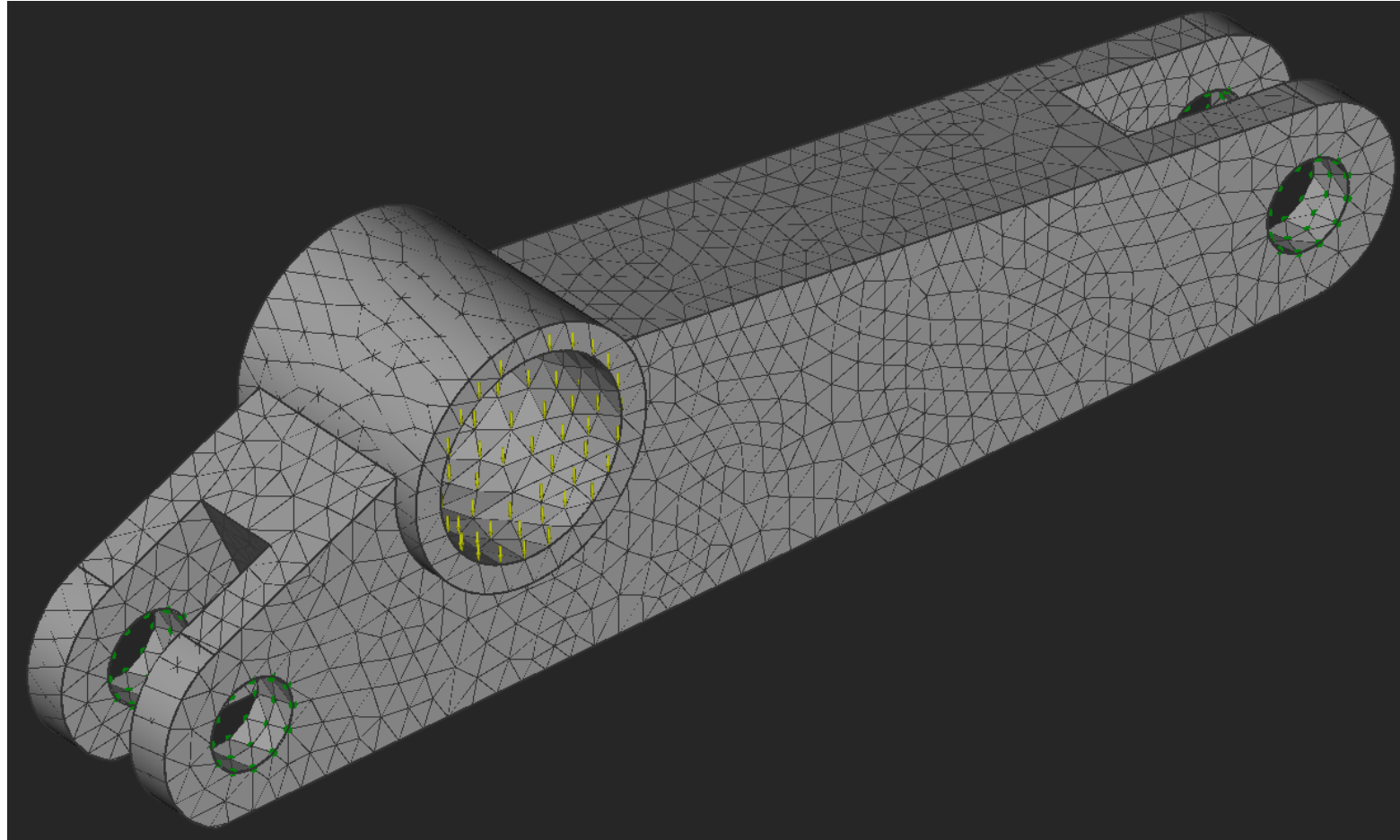

Define the Objective Function

The objective is what property, or design response, we hope to minimize or maximize within our part

Several design responses such as structural compliance, volume fraction, displacement, and stress

In this example, the objective is to minimize structural compliance

Define the Objective Function

Add a **Structural Compliance Response** block

Add the *Displacement Restraint* and the *Force* block from the boundary condition step

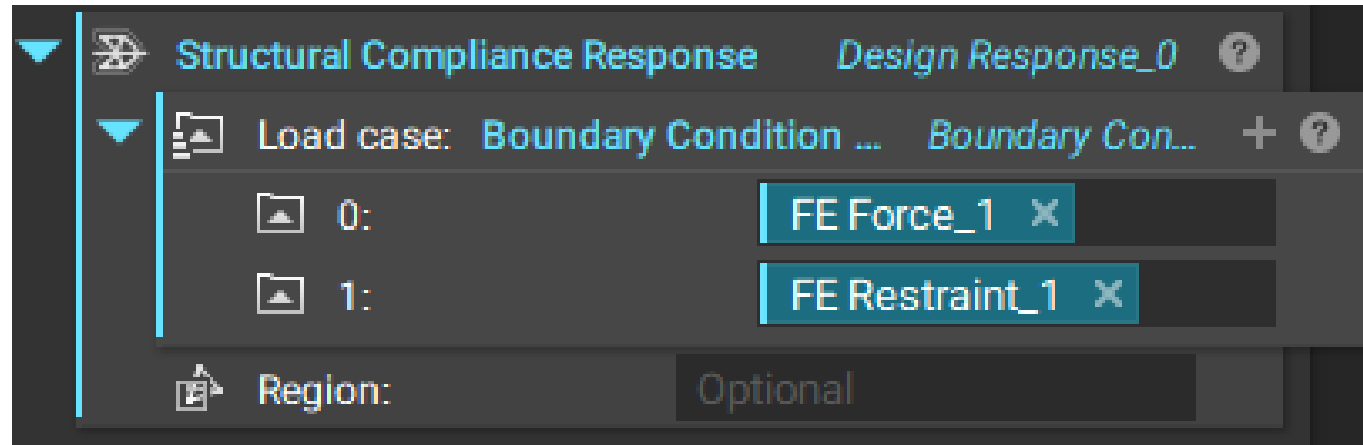

Define the Objective Function

Add an **Optimization Objective** block

Set the goal to Minimize and insert the Structural Compliance Response into the Design Response List

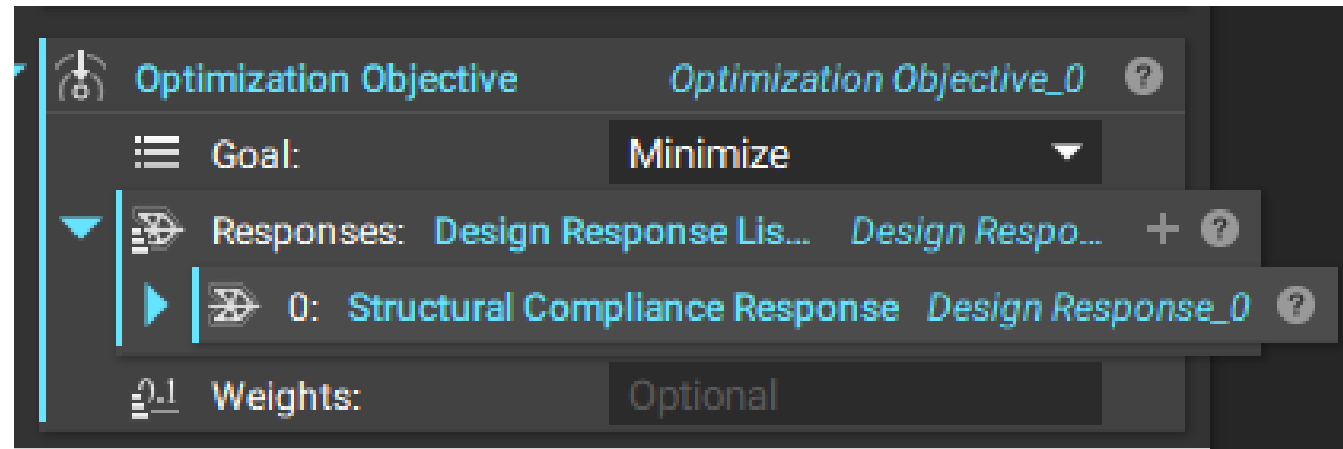

Define the Objective Function

Add the appropriate constraint for the optimization fraction

Add an **Optimization Constraint List** block, then Insert a **Volume Fraction Response** block into the Response input

In this example we are going to use the volume fraction constraint in 0.2 value

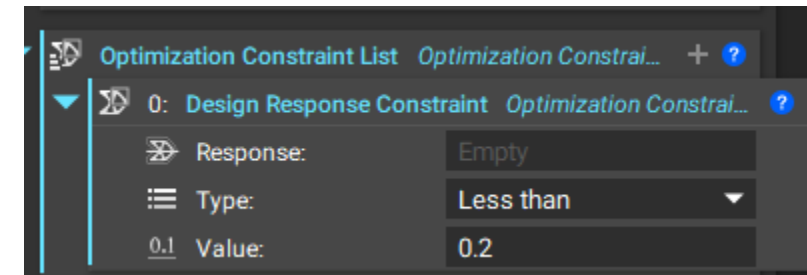
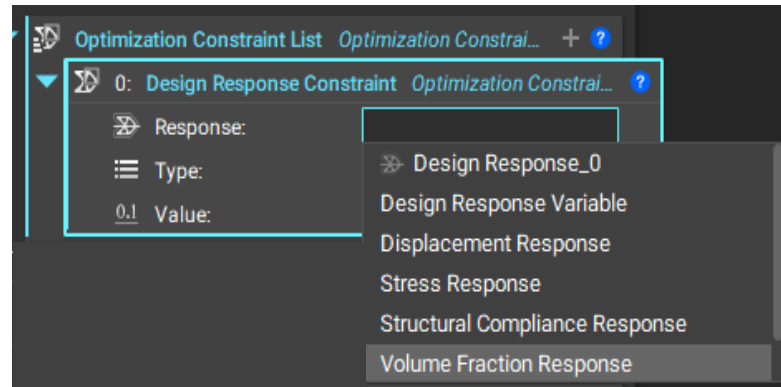
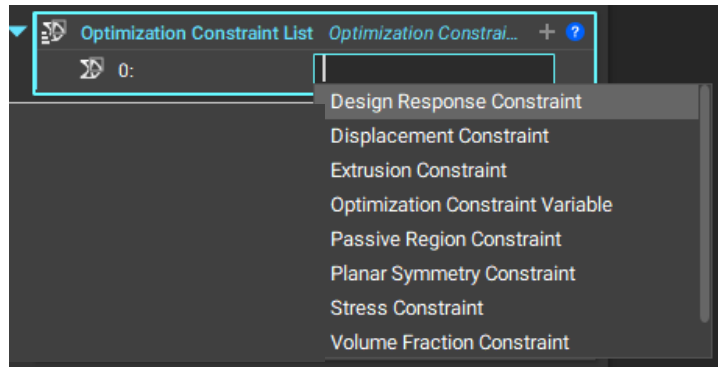

Run the Topology Optimization

Add a **Topology Optimization** block, Insert the FE Model, Insert the Objective, Insert the Constraints and set the other parameters

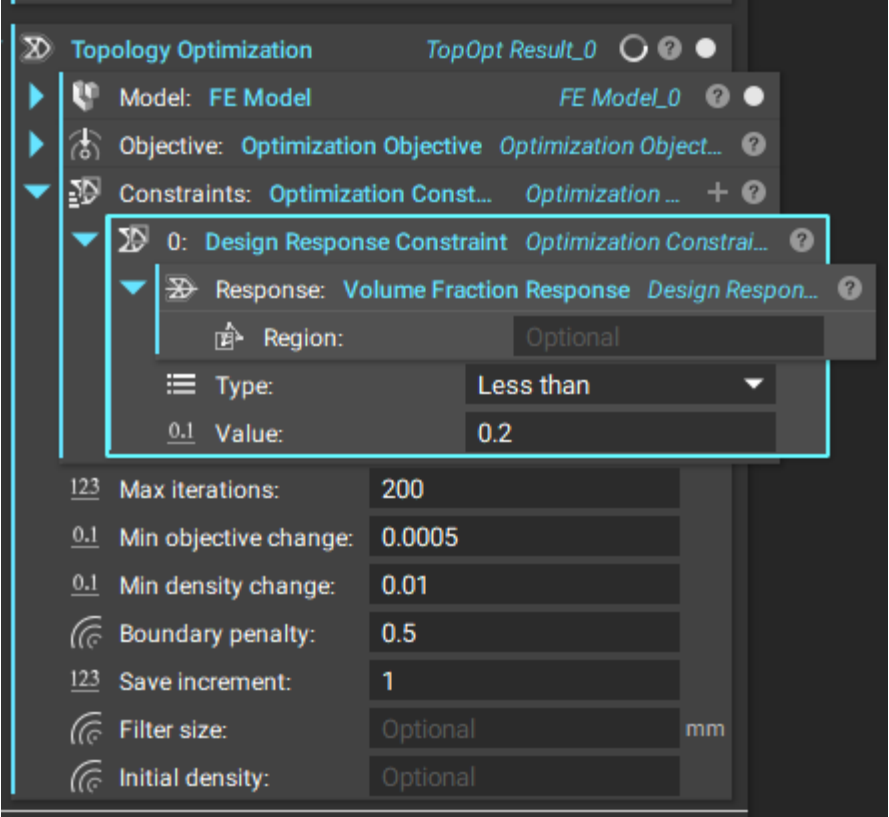

Run the Topology Optimization – Results-

Topology Optimization *TopOpt Result_0*

- Model: FE Model *FE Model_0*
- Objective: Optimization Objective *Optimization Object...*
- Constraints: Optimization Const... *Optimization ...*
 - 0: Design Response Constraint *Optimization Constrai...*
 - Response: Volume Fraction Response *Design Respon...*
 - Region: Optional
 - Type: Less than
 - Value: 0.2

123	Max iterations:	100
0.1	Min objective change:	0.0005
0.1	Min density change:	0.01
	Boundary penalty:	1
123	Save increment:	1
	Filter size:	Optional mm
	Initial density:	Optional

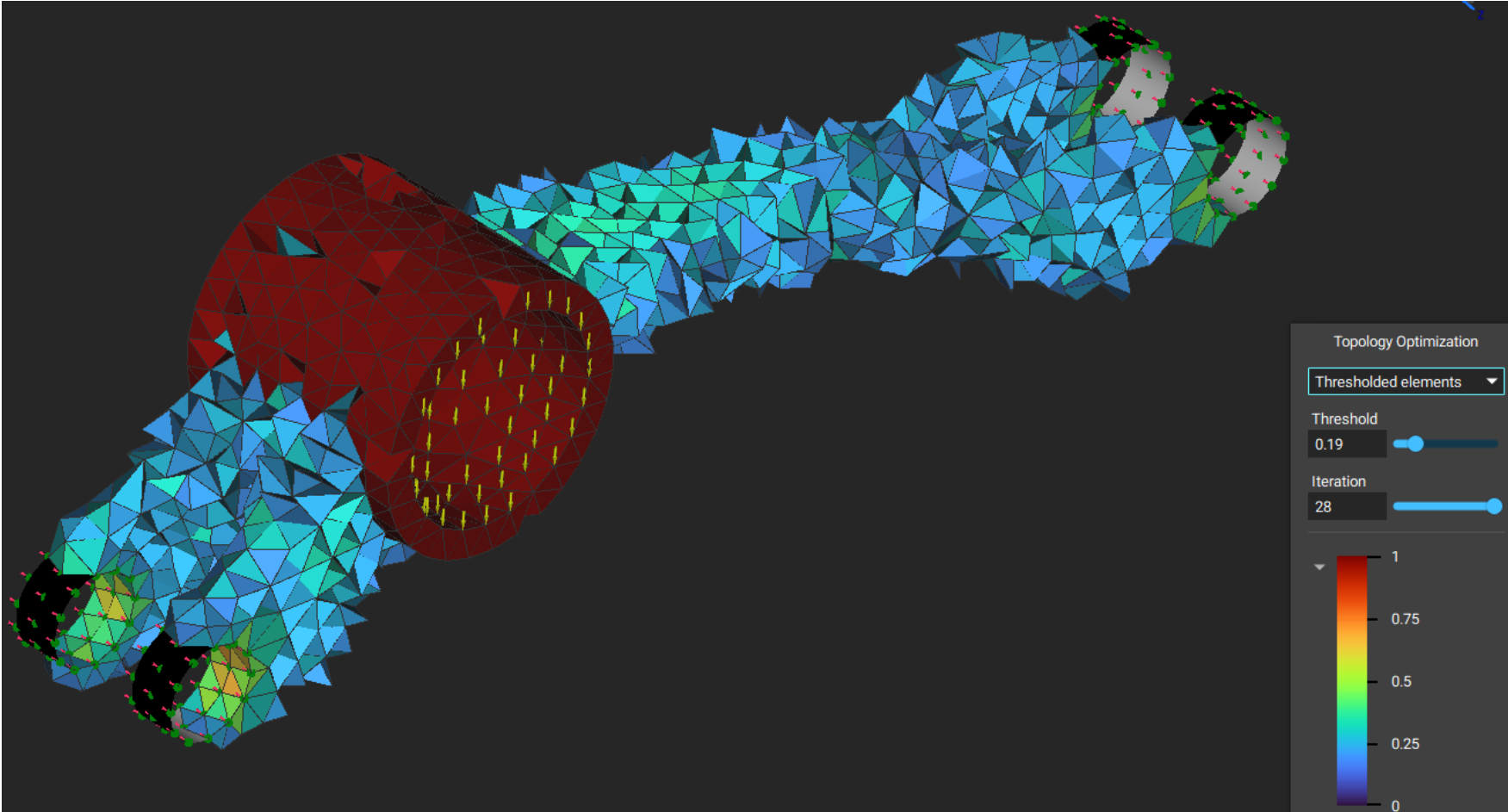

Run the Topology Optimization – Results-

Topology Optimization

Model: FE Model FE Model_0

Objective: Optimization Objective Optimization Object...

Constraints: Optimization Const... Optimization ... +

0: Design Response Constraint Optimization Constrai...

Response: Volume Fraction Response Design Respon...

Region: Optional

Type: Less than

Value: 0.2

123 Max iterations: 100

0.1 Min objective change: 0.0005

0.1 Min density change: 0.01

Boundary penalty: 0

123 Save increment: 1

Filter size: Optional mm

Initial density: Optional

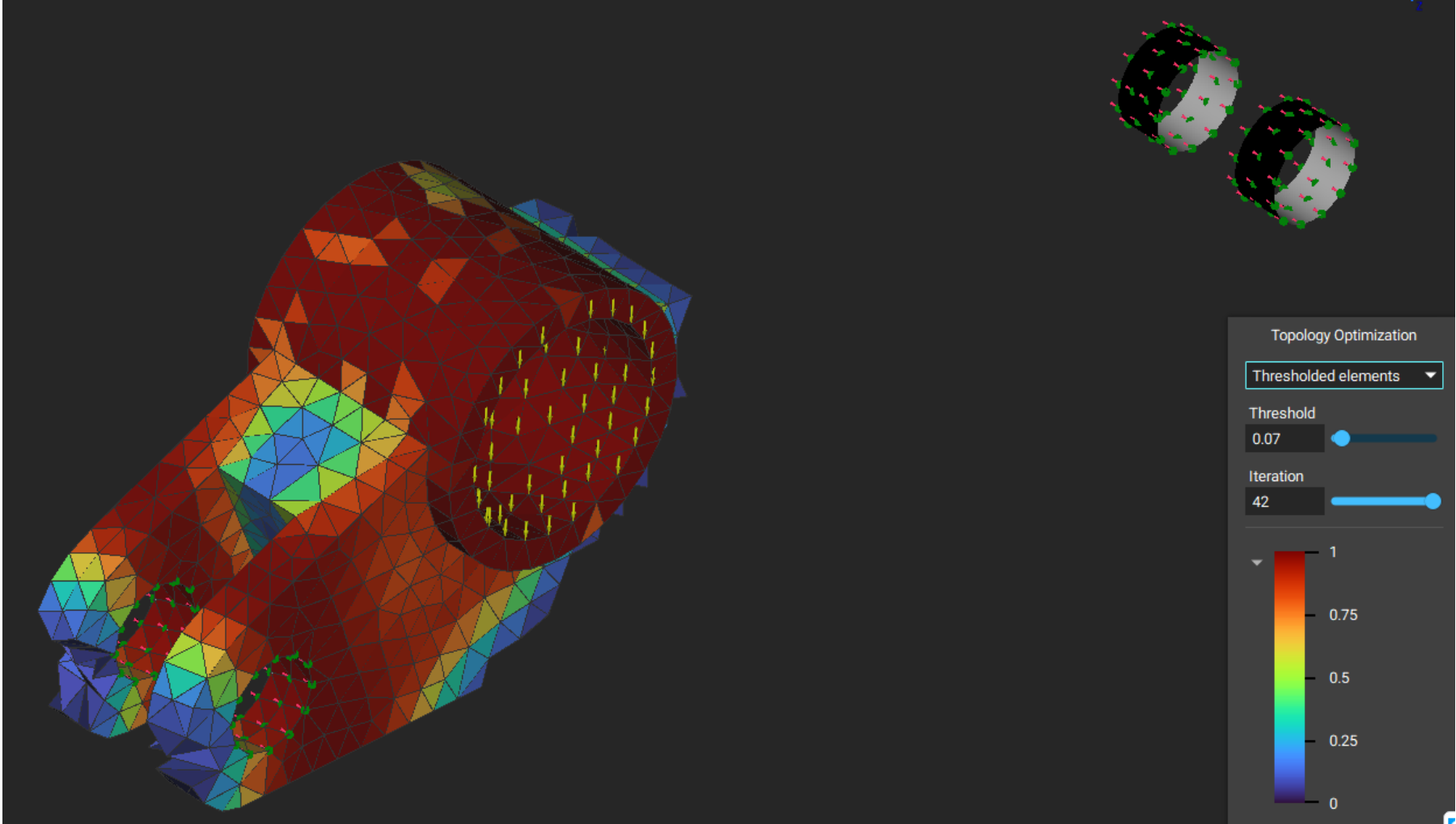

Run the Topology Optimization – Results-

Topology Optimization TopOpt Result_0

- Model: FE Model FE Model_0
- Objective: Optimization Objective Optimization Object...
- Constraints: Optimization Const... Optimization ... +
 - 0: Design Response Constraint Optimization Constrai...
 - Response: Volume Fraction Response Design Respon...
 - Region: Optional
 - Type: Less than
 - Value: 0.3

123 Max iterations: 100

0.1 Min objective change: 0.0005

0.1 Min density change: 0.01

Boundary penalty: 0.3

123 Save increment: 1

Filter size: Optional mm

Initial density: Optional

FE Force_1 Force

- Boundary: FE Boundary by Body FE Boundary_0
- Mesh: FE Mesh_1
- Entity: Nodes
- Body: Implicit Body_3
- Reverse:
- Tolerance: 0.001 mm

Vector: 0 -400 0 N

Frame: Optional

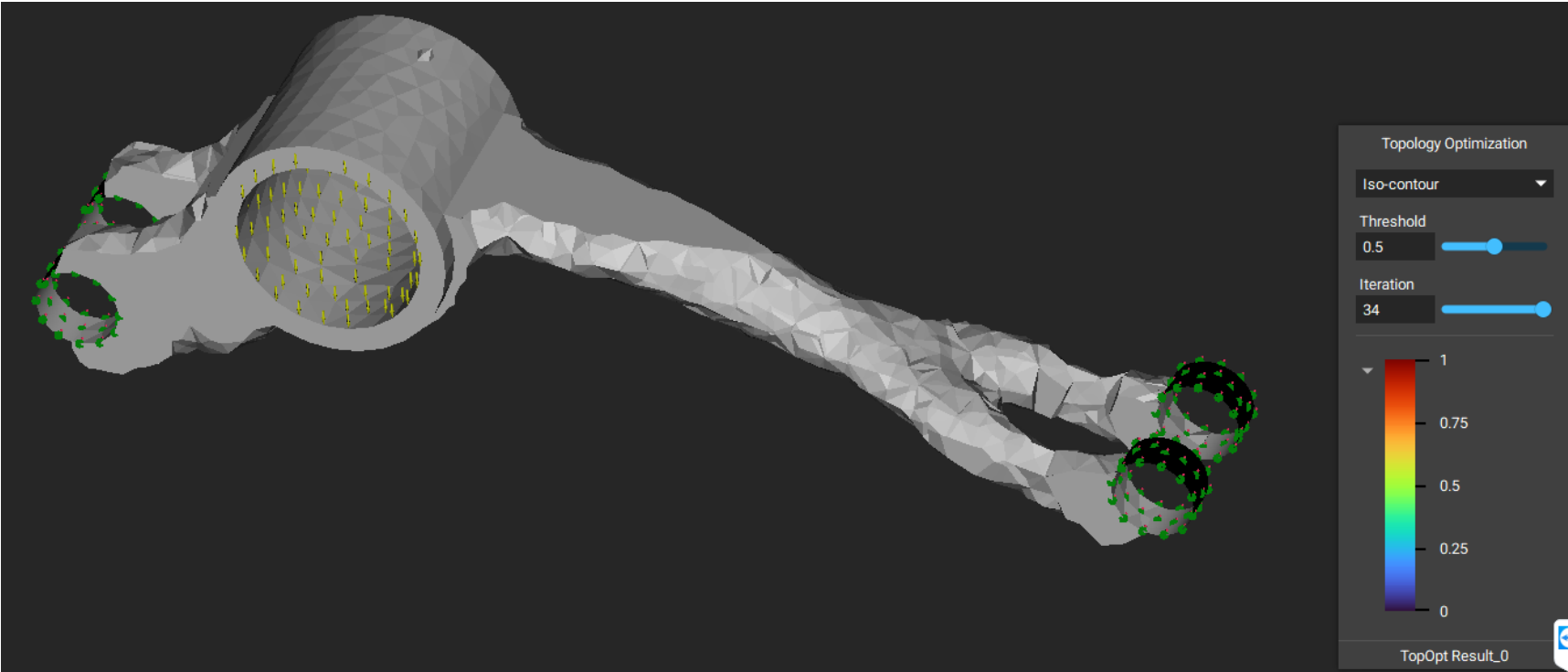

Run the Topology Optimization (b.p.=0.5) – Results-

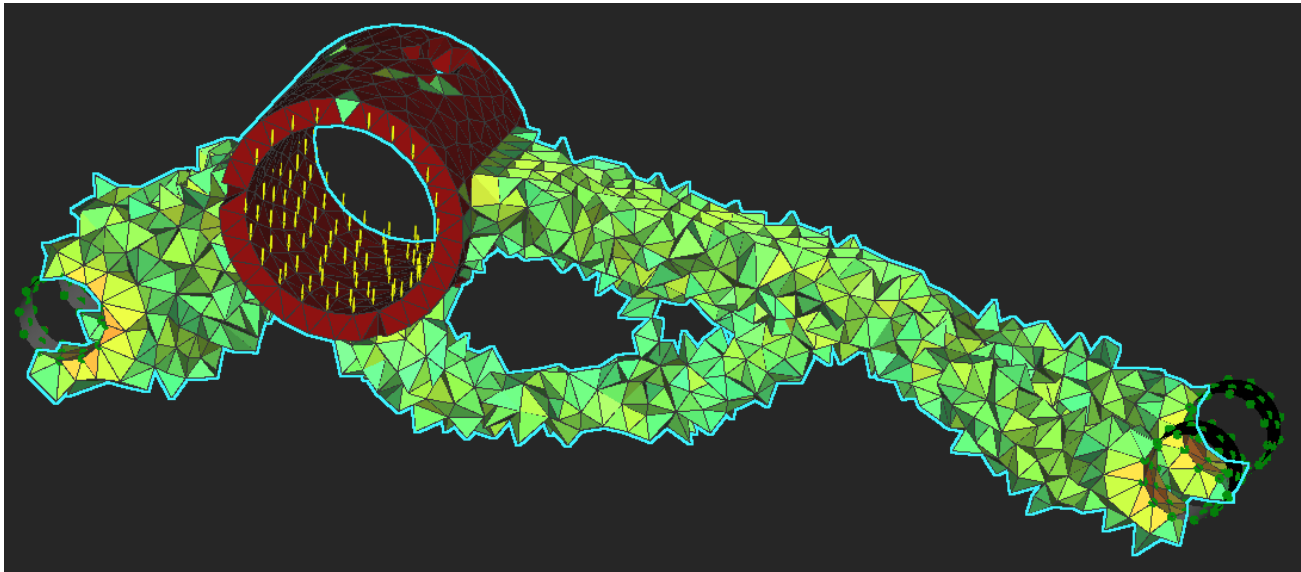
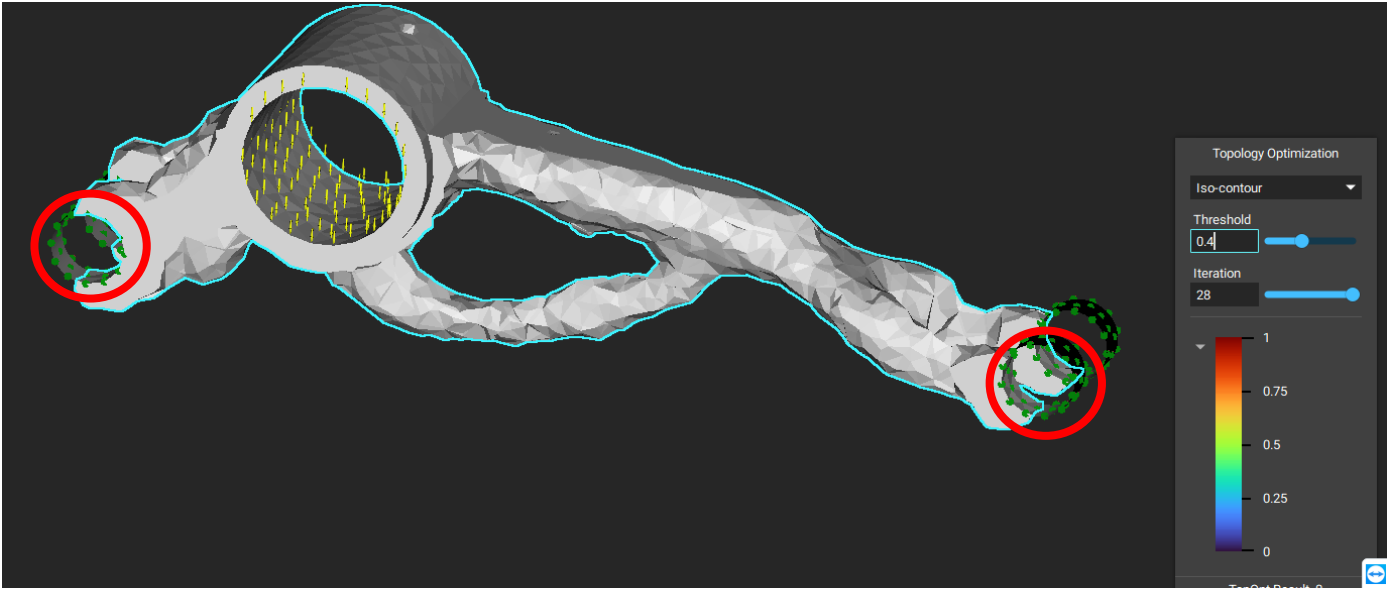

Implicit Body

Add an **Implicit Body from Topology Optimization Results** block

Input the Topology Optimization block

Set the Threshold value the selected value

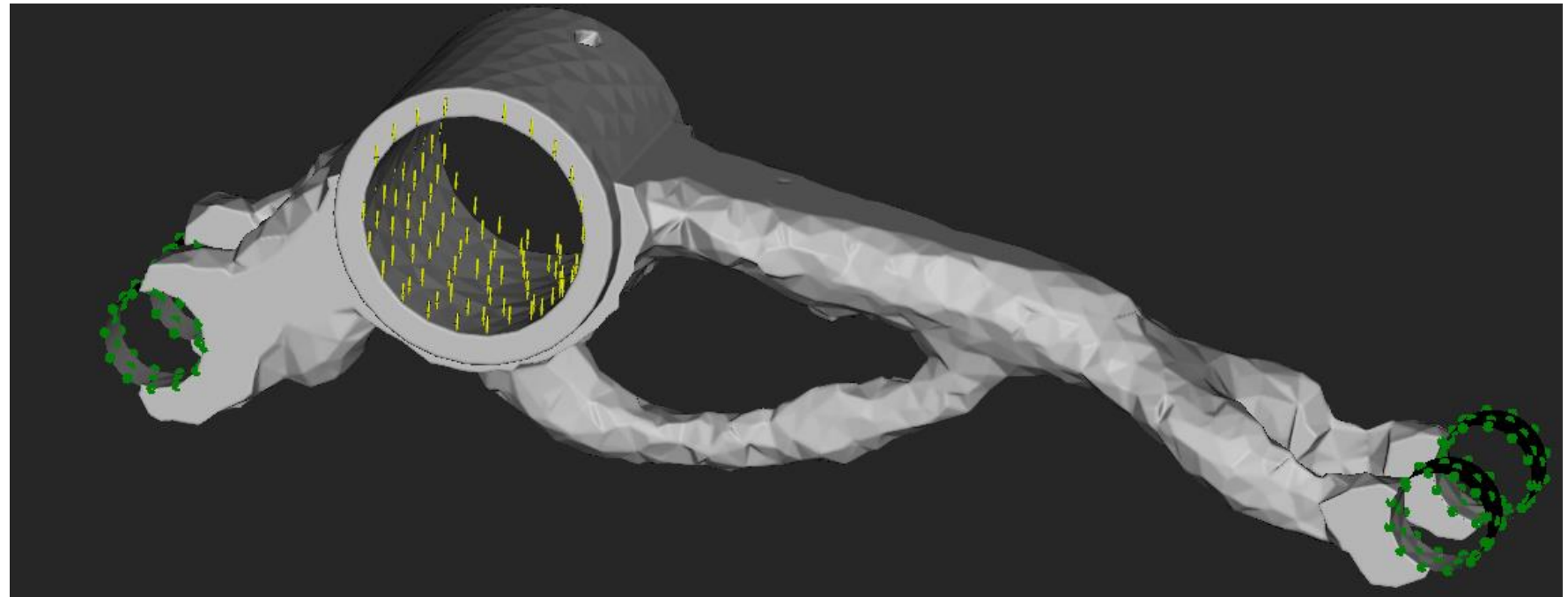
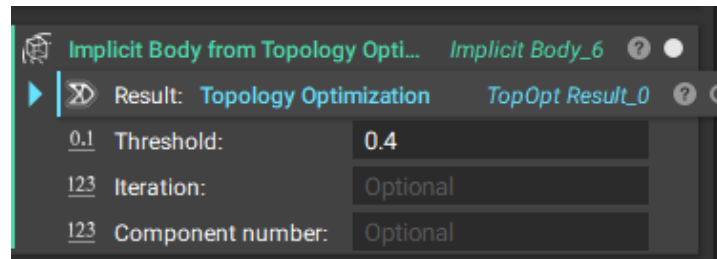

TO Constraints - Define Passive Regions-

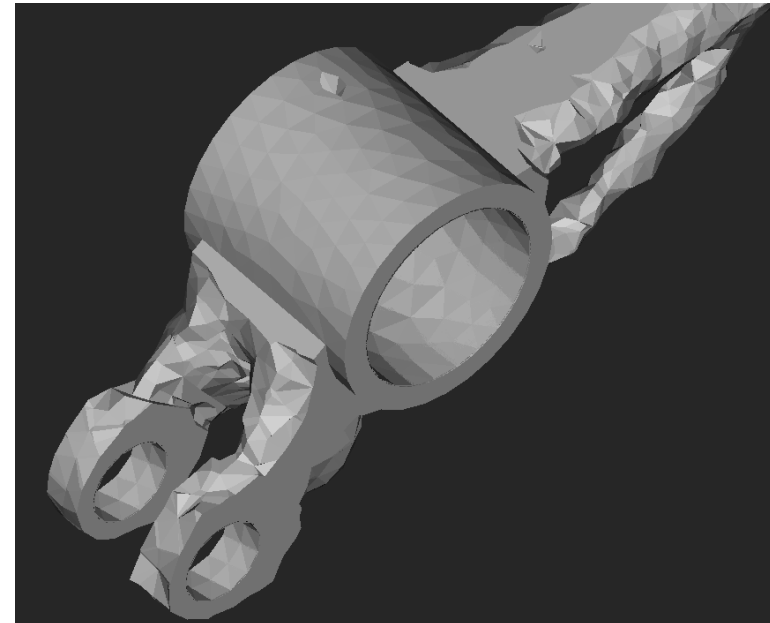
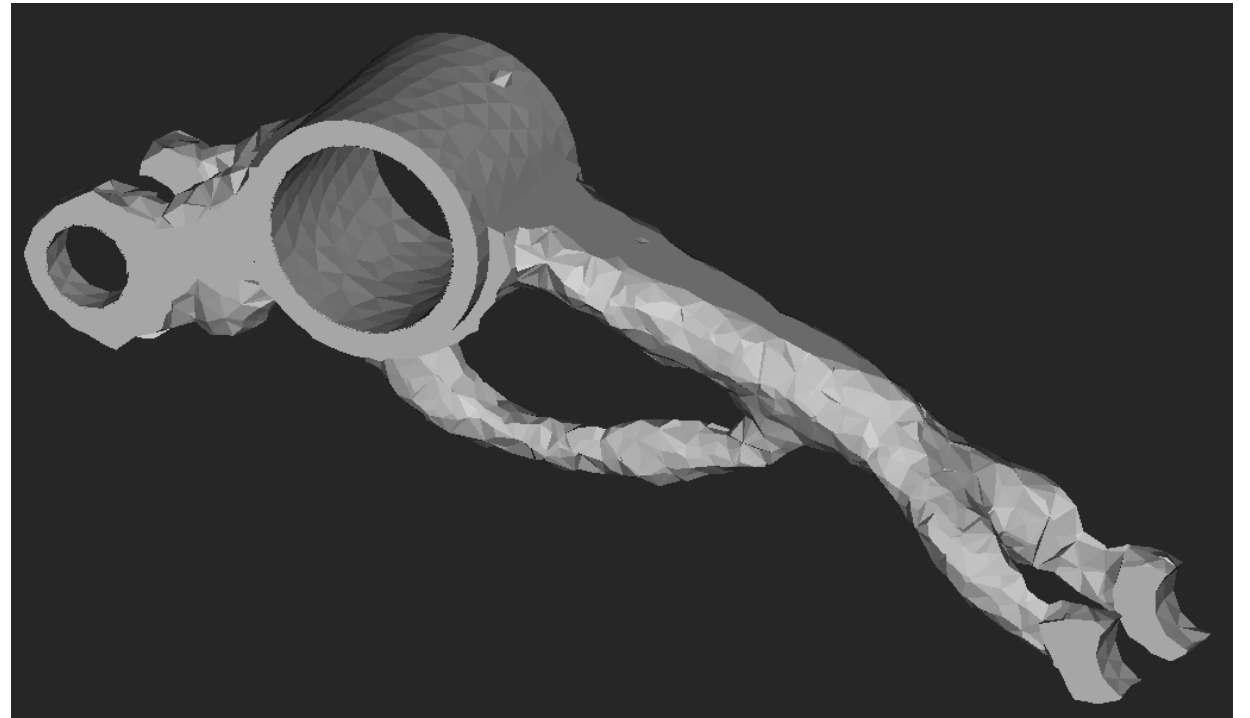
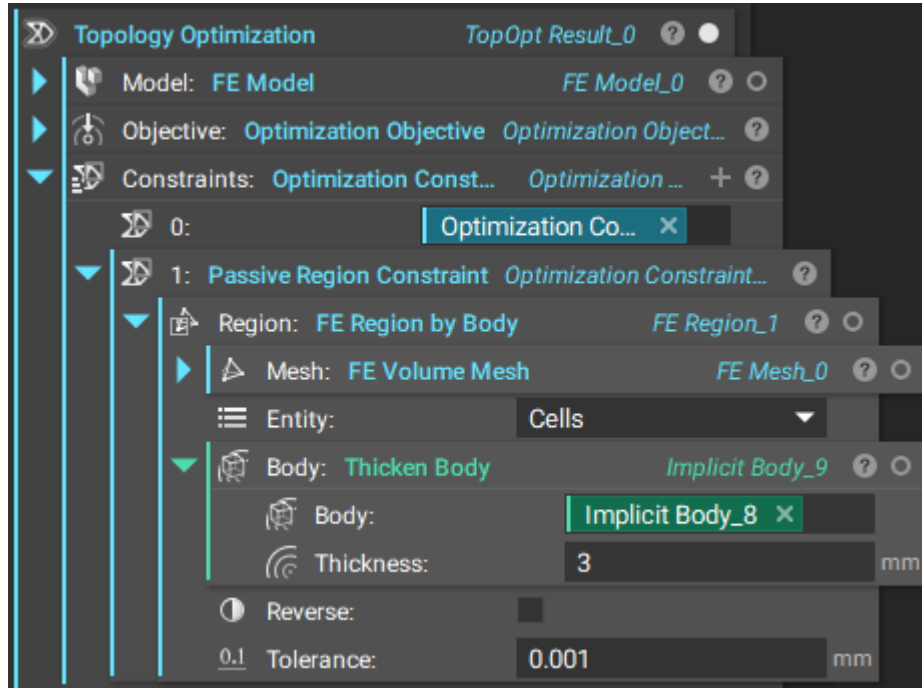

TO Constraints -Define Passive Regions-

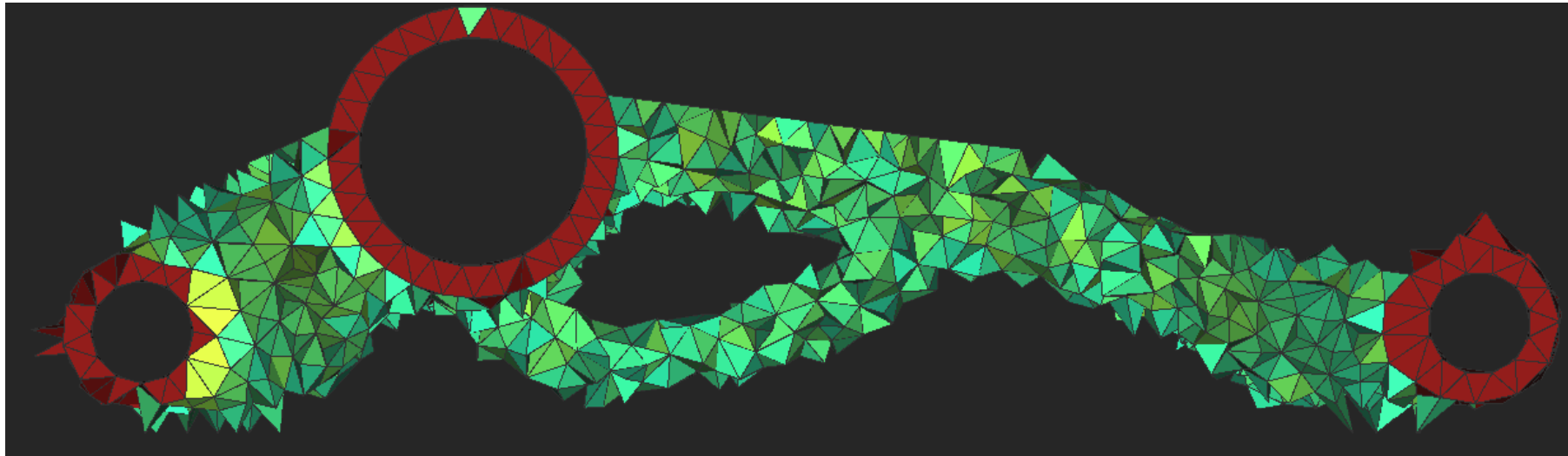
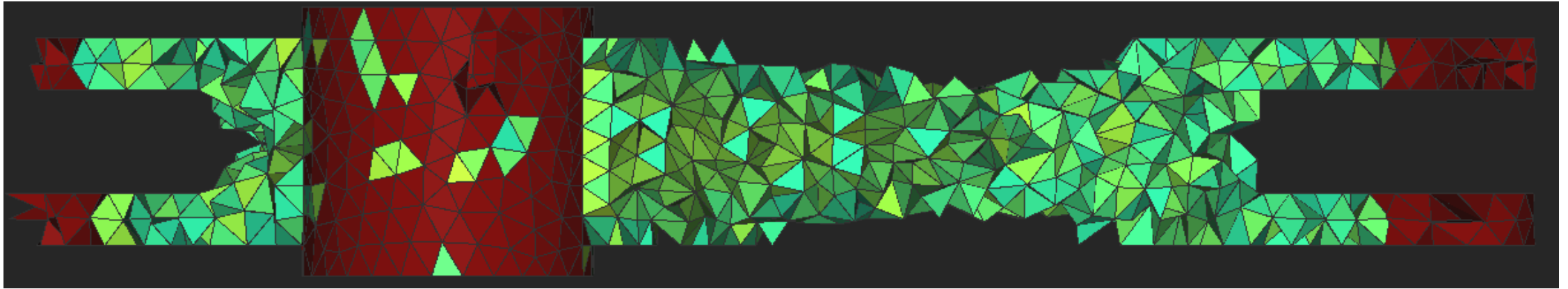

Additive Manufacturing Supports

The support is an additional lightweight structure that supports the model where the next layer would be printed ‘in the air’. After printing, the support is removed by breaking or dissolving

Printing a support is always a cost. Printing time is longer and the amount of material used is higher. Therefore, it is important to adjust the max overhang angle so that the supports are used only where they are most necessary



Source: <https://omni3d.com/>

Additive Manufacturing Supports- Overhang Angle-

The main factor optimizing the supports, is the parameter of the **MOA** (Max Overhang Angle), two factors are critical:

a) Path Width, b) Layer height

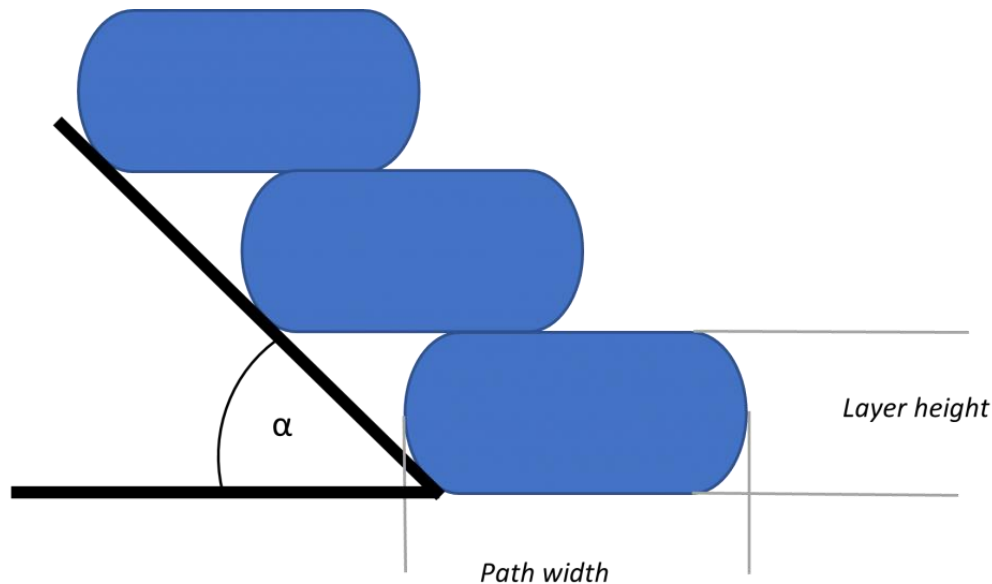

$$\alpha = \tan^{-1} \frac{d * (1 - f)}{h}$$

α - maximum overhang angle
 d - width of the printed path
 f - percentage overlap
 h - layer height

Additive Manufacturing Supports- Overhang Angle-

max overhang angle for common settings

		Path width [mm]		
		0,3	0,4	0,5
Layer height [mm]	0,1	63°	69°	73°
	0,15	53°	60°	66°
	0,2	45°	53°	59°
	0,25	38°	47°	53°
	0,3	33°	41°	48°
	0,35		37°	43°
	0,4		33°	40°

Source: <https://omni3d.com/>

Additive Manufacturing Supports

Add a **Manufacturing Support Volume** block

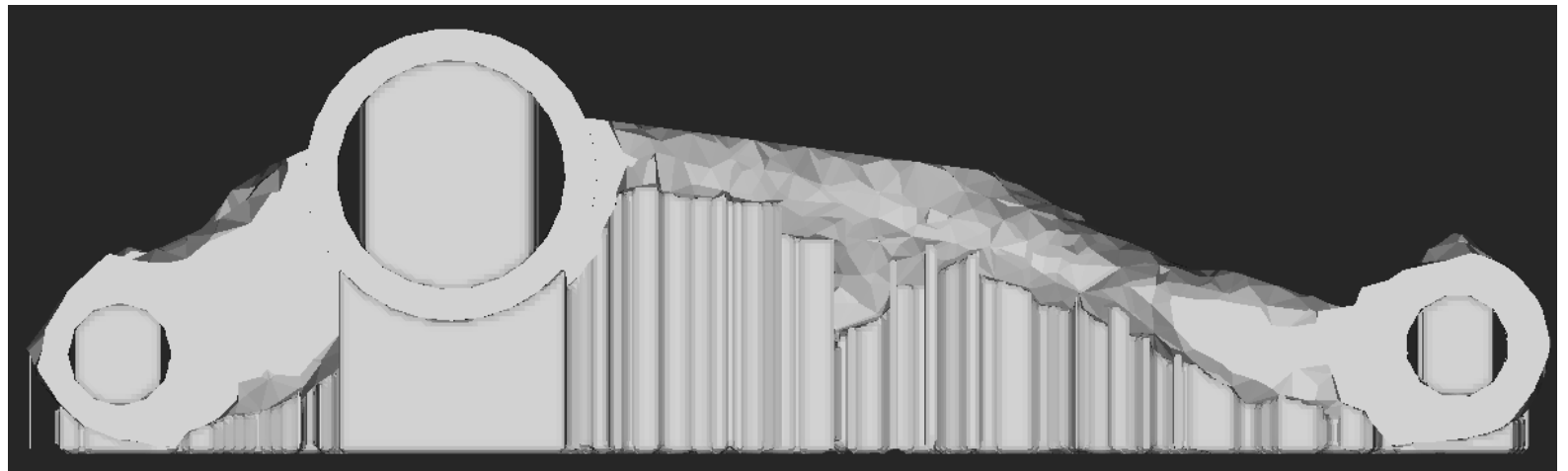
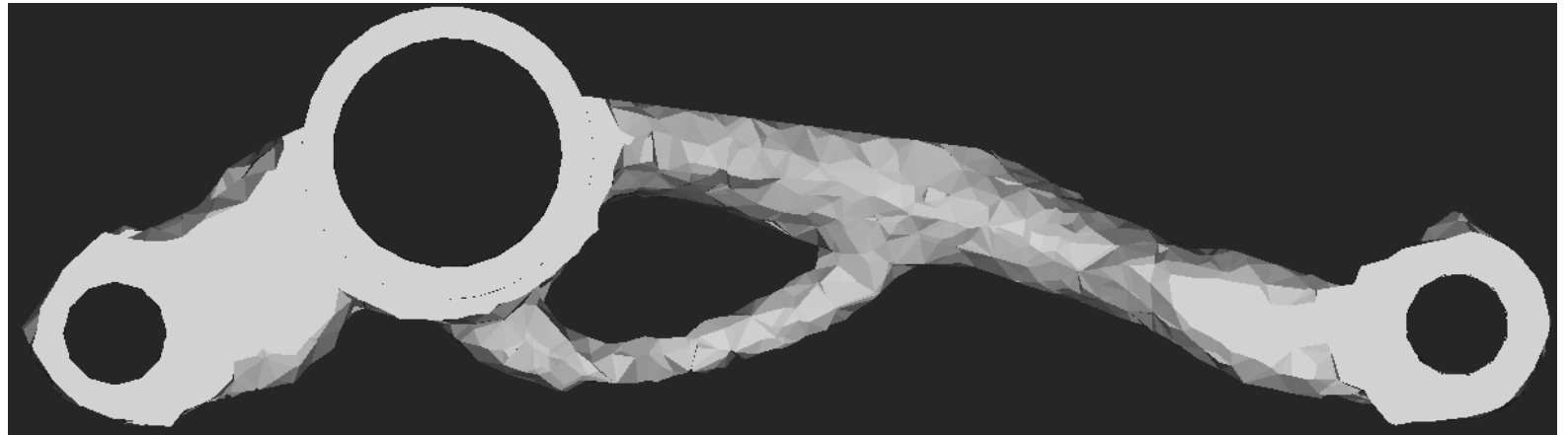
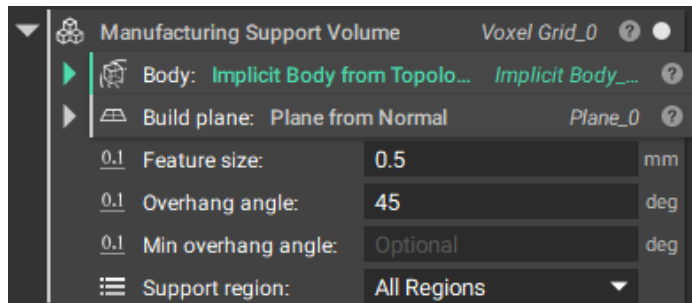

Supports Optimization

Add a **Minimum Support Orientation Block**

Definition of the best orientation angle

The Supports volume is depended on printing angle

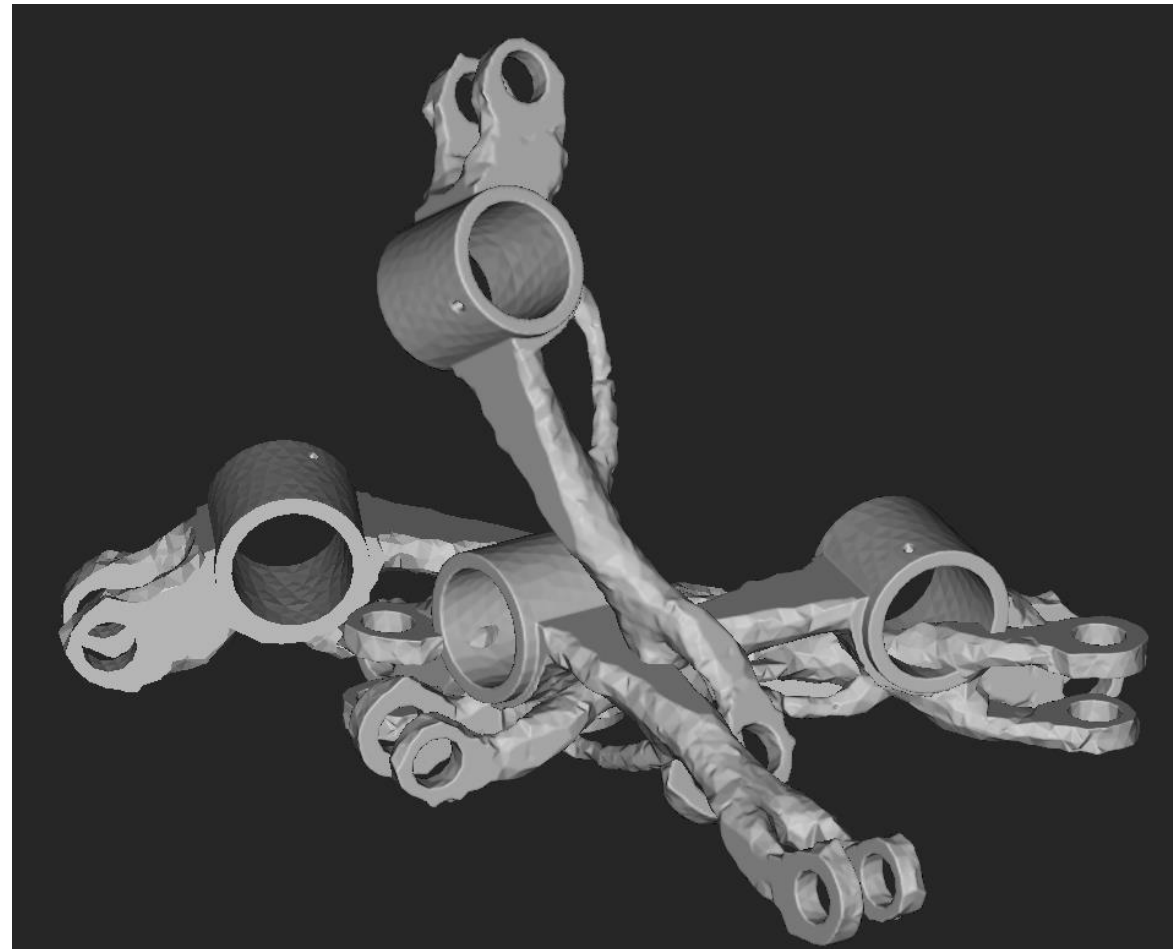
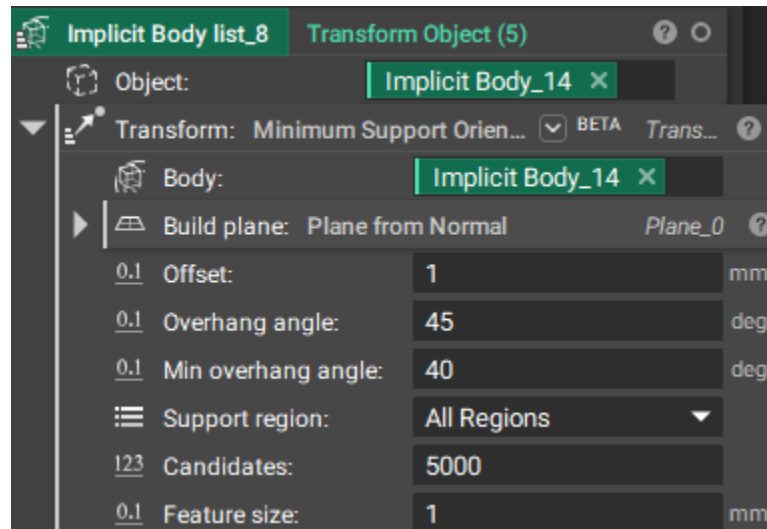

Supports Optimization

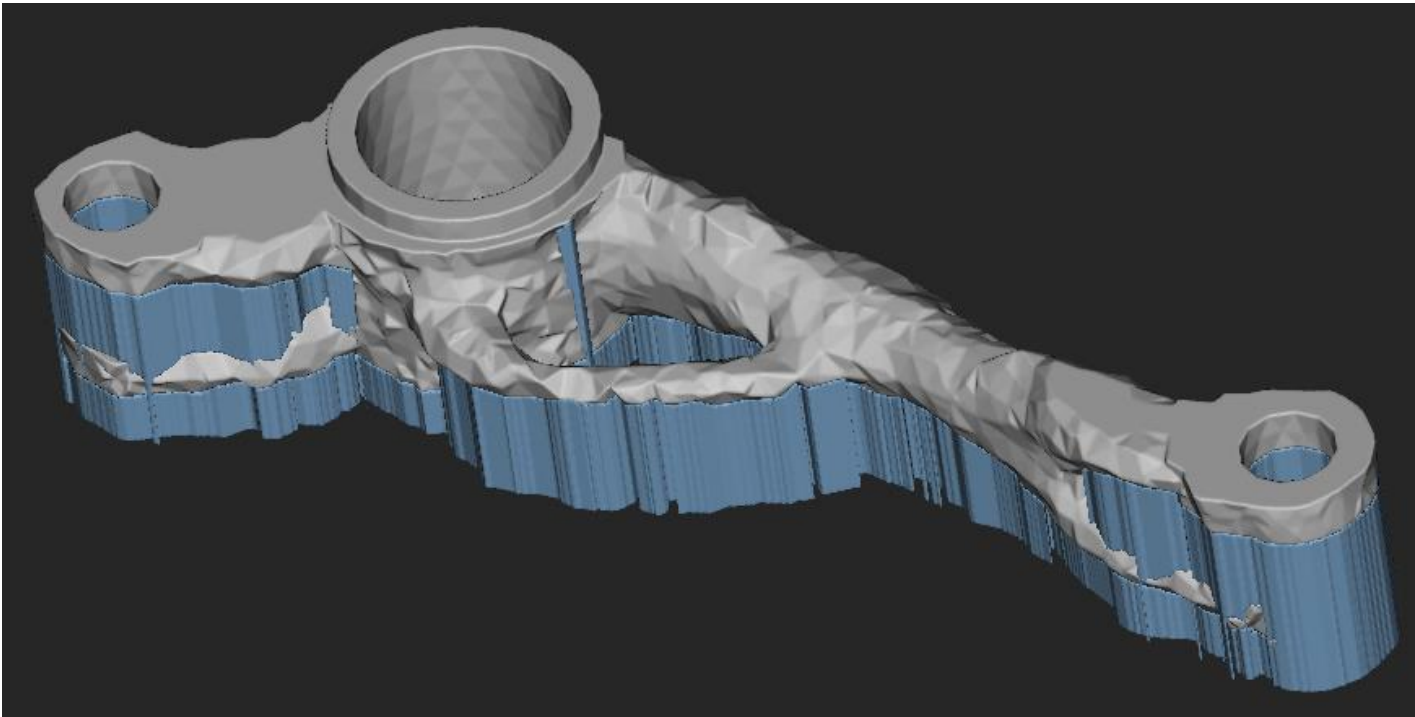

Manufacturing Support Volume (5) Voxel Grid_2

Body: Implicit Body lis... x

Build plane: Plane from Normal Plane_4

Origin: 0 0 0 mm

Normal: 0 1 0

Feature size: 1 mm

Overhang angle: 45 deg

Min overhang angle: Optional deg

Support region: All Regions

Sort (5) Any_3

List: Implicit Body lis... x

Proxy: Voxel Grid_2.act... x

Manufacturing Support Volume Voxel Grid_3

Body: Implicit Body 22... x

Information Properties Display Comment

Object Name: Voxel Grid_2

Object Structure

- Voxel Grid_2 (5)
 - Properties
 - active voxel count (5)
 - Properties
 - 123 active voxel count [0] 193.930
 - 123 active voxel count [1] 60.258
 - 123 active voxel count [2] 60.258
 - 123 active voxel count [3] 81.242
 - 123 active voxel count [4] 86.371
 - bounding box (5)

Supports Optimization

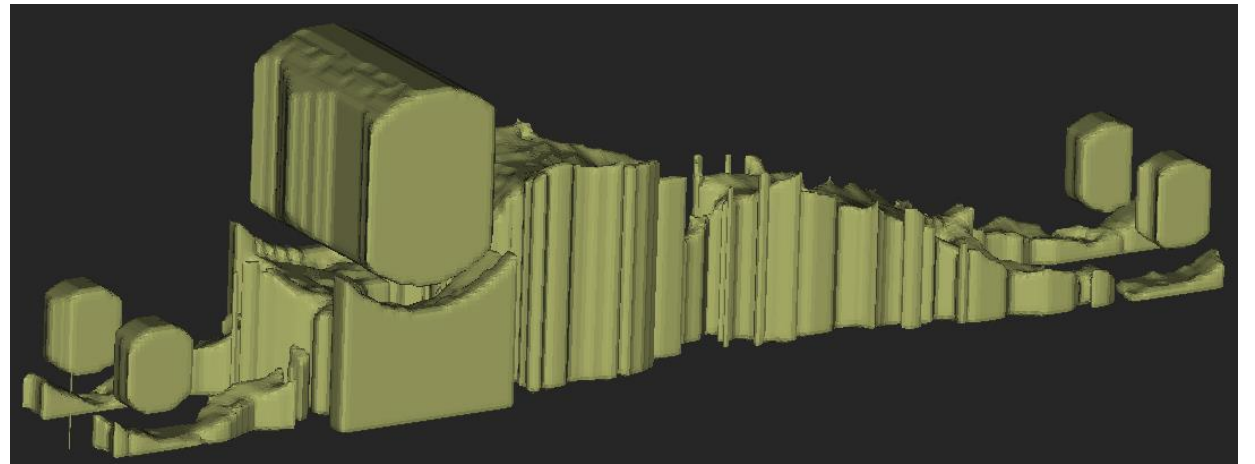
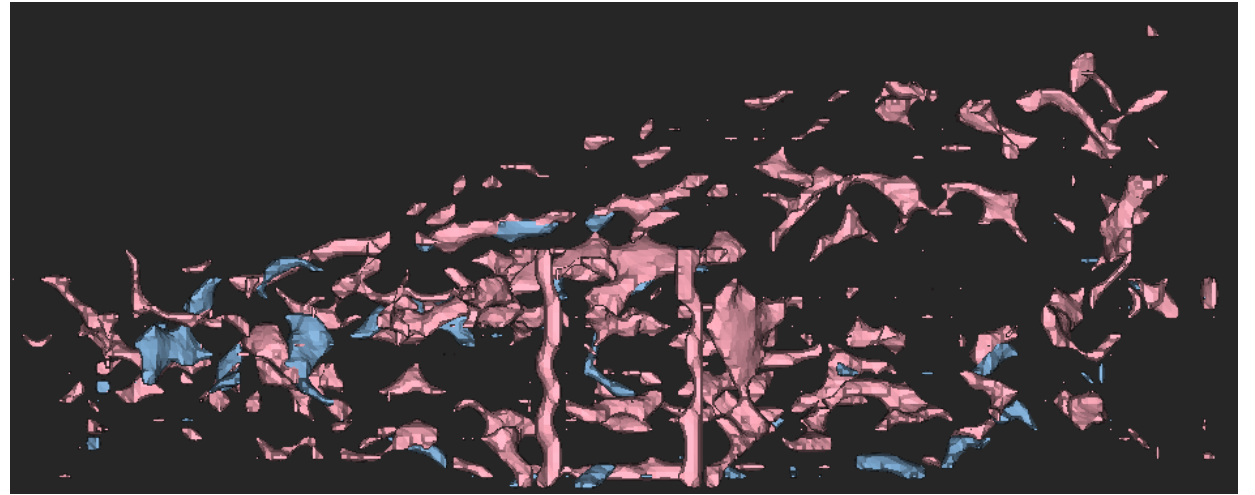
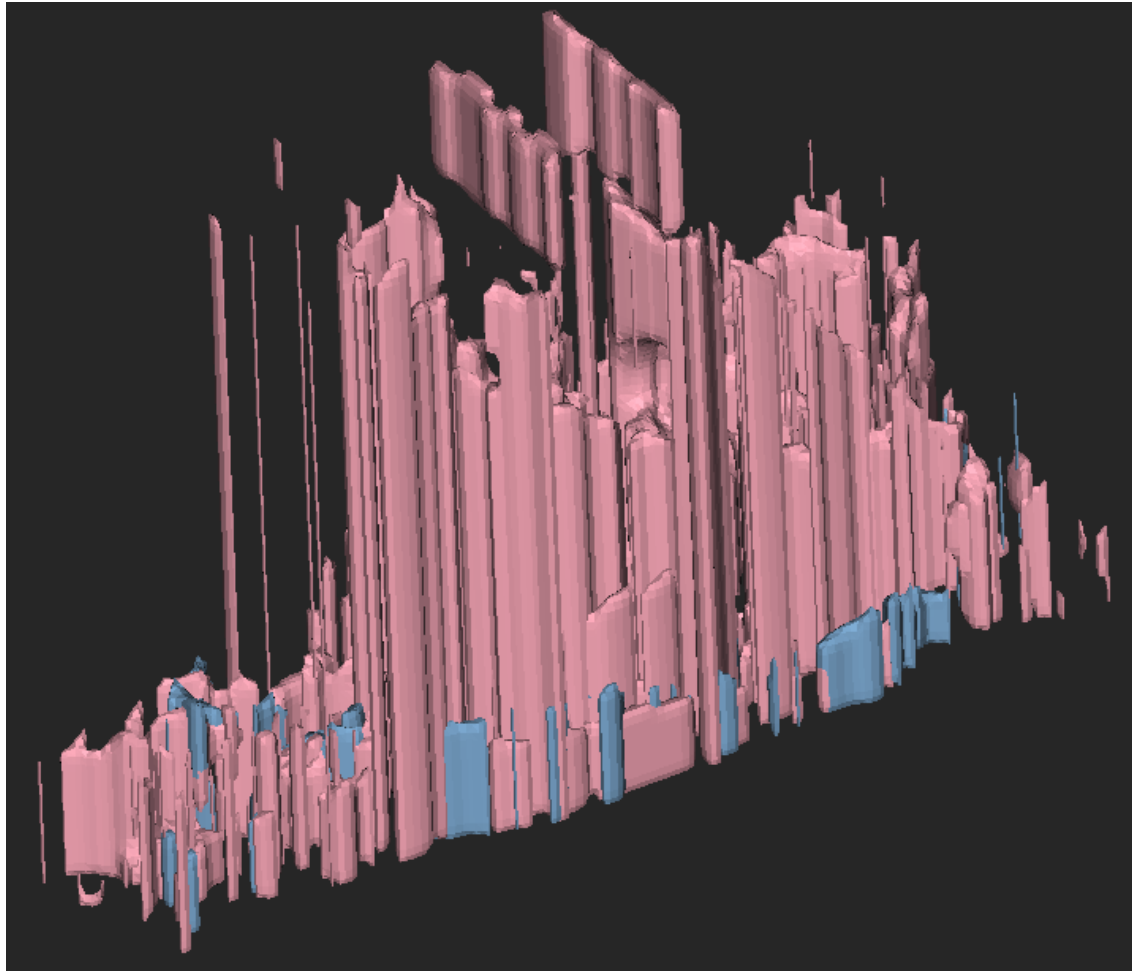

TO Constraints –Overhang Angle

Add an **Overhang Constraint** block

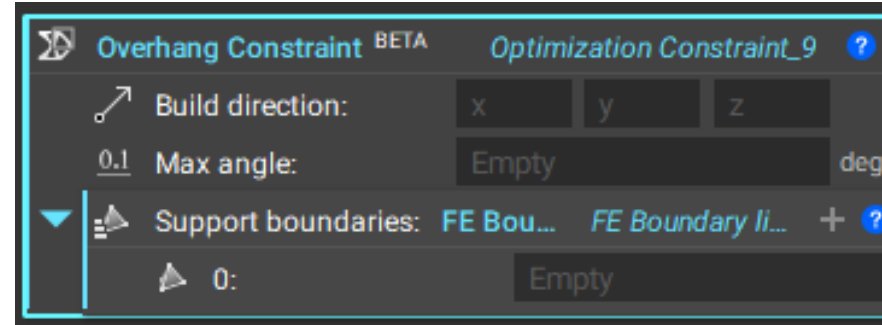

File > Settings and enable Show Beta Blocks

Define the Build direction as a vector. This corresponds to the direction of manufacture.

Specify the max angle, which is the maximum allowable overhang angle allowed by the manufacturing process

Specify the support boundaries, which are the regions you want to allow support structures to be applied to.

The Overhang Constraint can now be input into the Constraints list of an existing Topology Optimization.

Post-Processing...

Add a **Smoothen Body** block, input a **Divide** block into the Grid Size

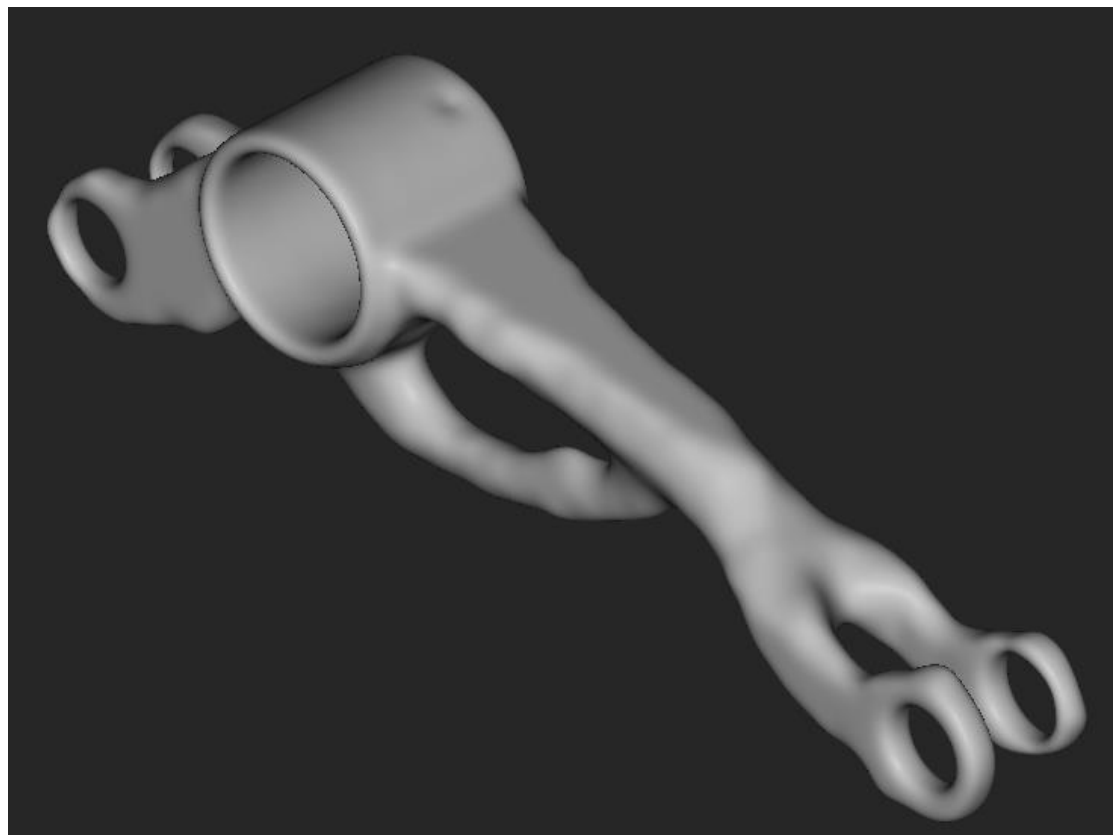
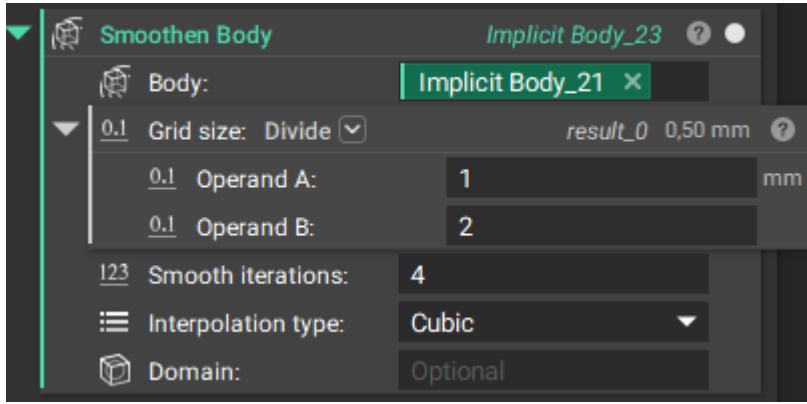

Volume Lattice

Add a **Shell and Volume Lattice** block

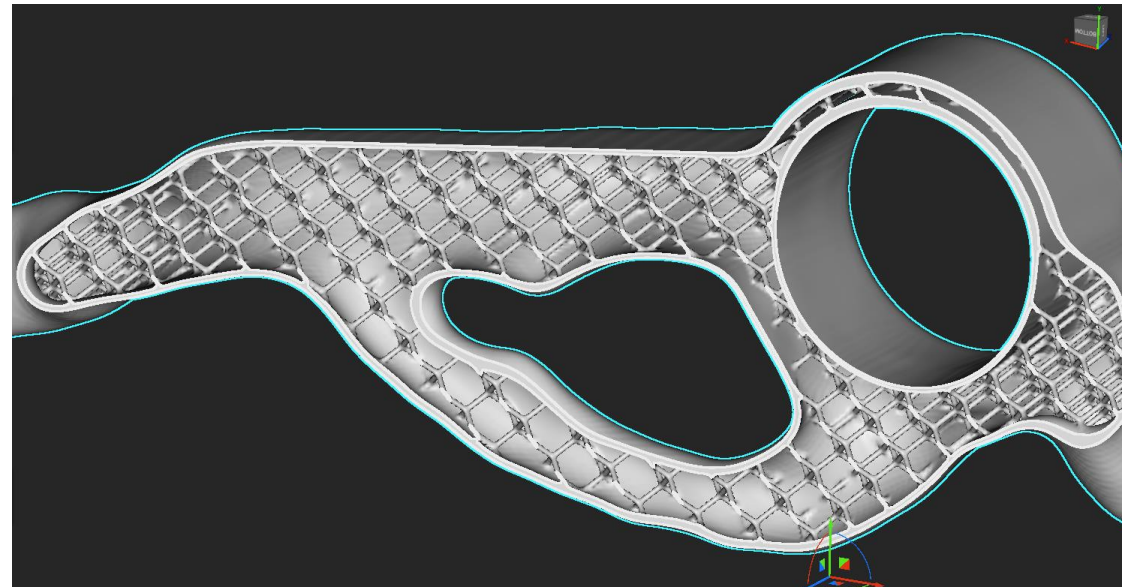
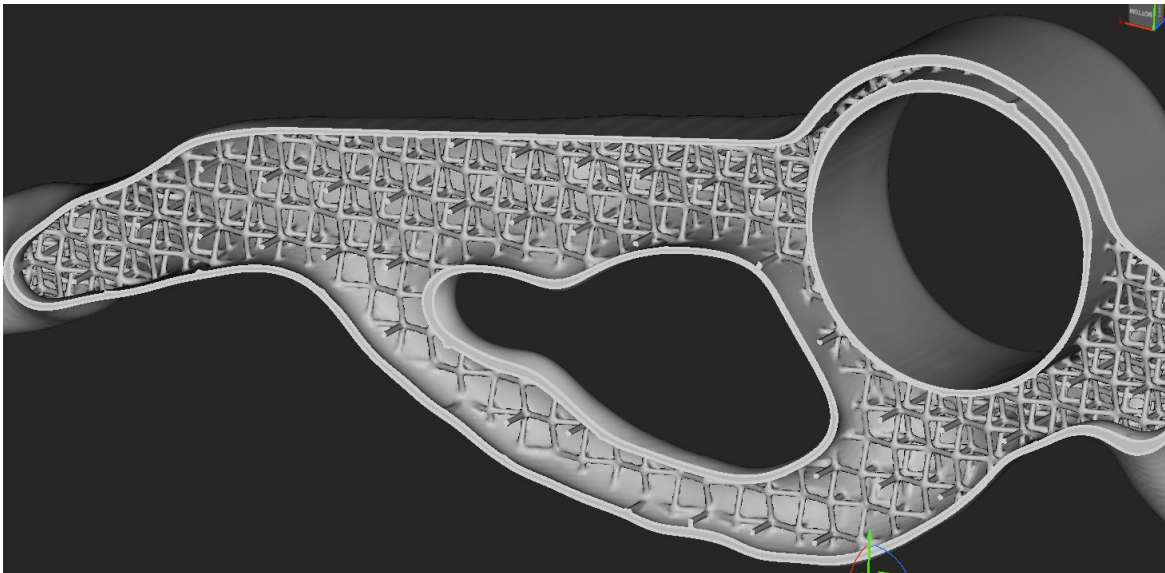
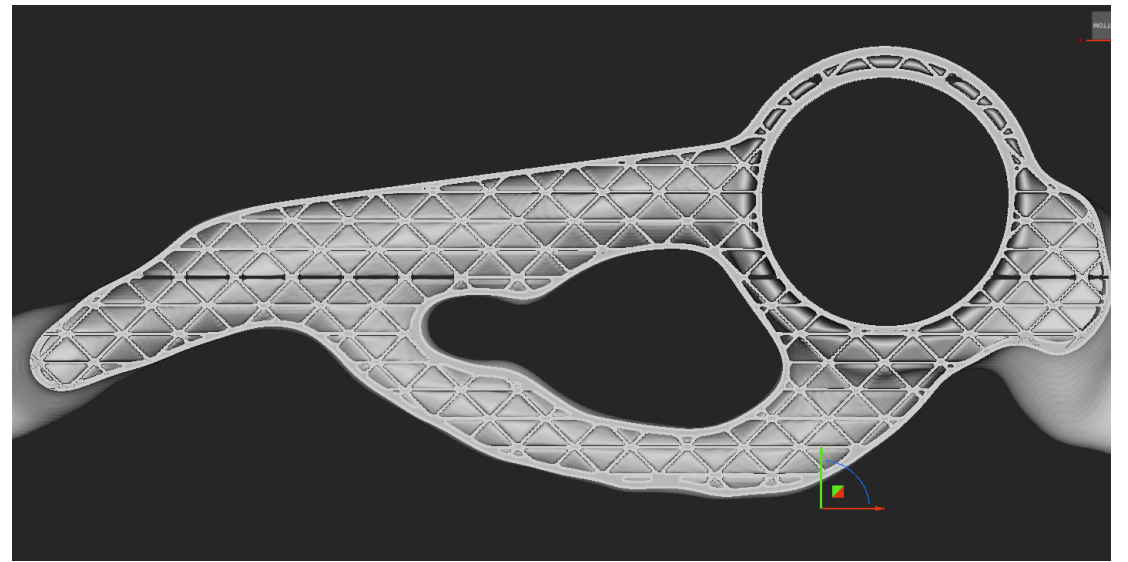
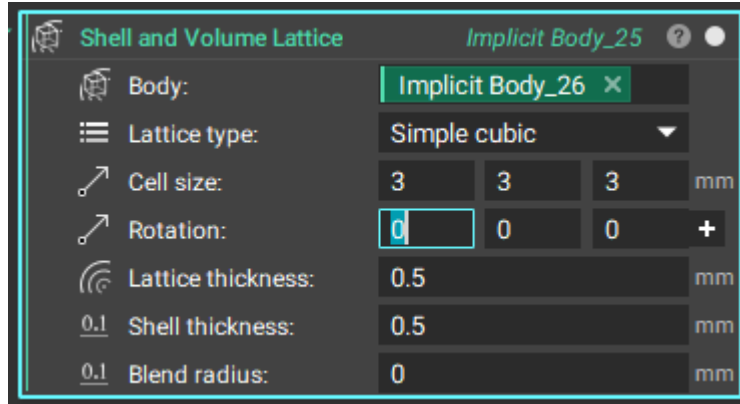

Slicing

Add a **Slice body** block

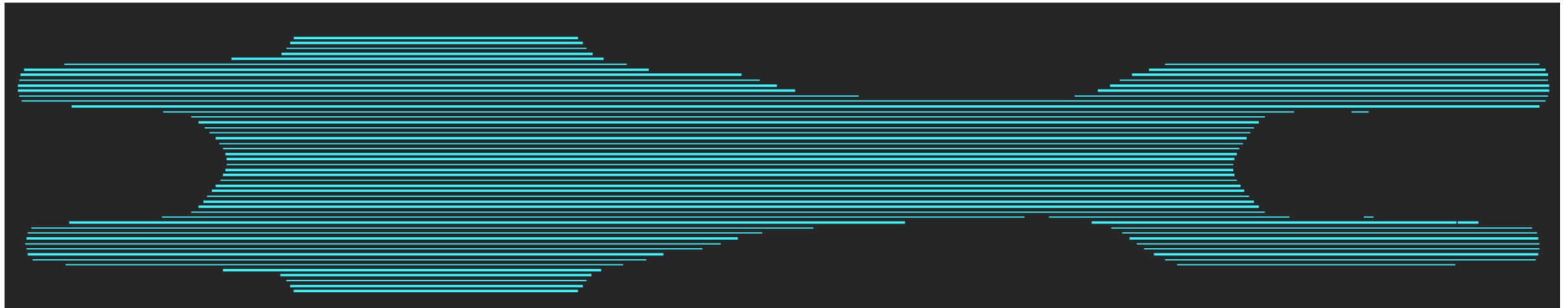
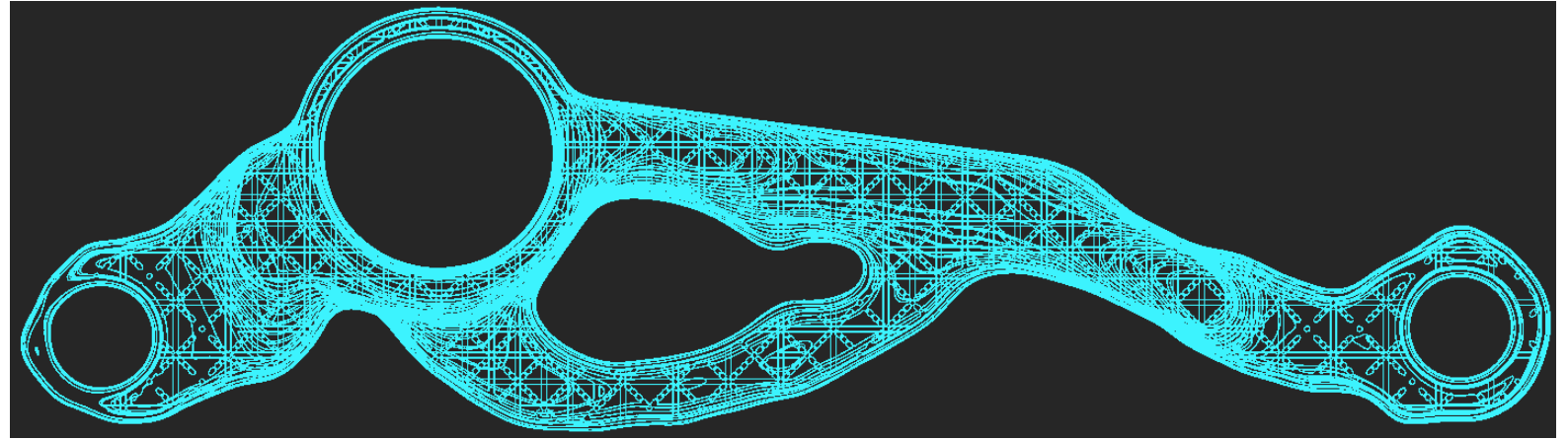
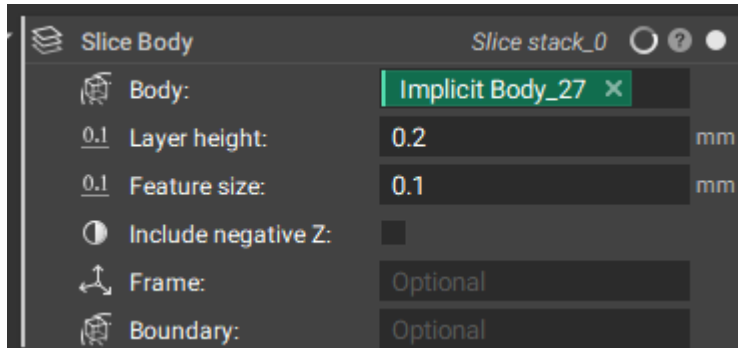

Slice Supports

Add a **Slice body** block

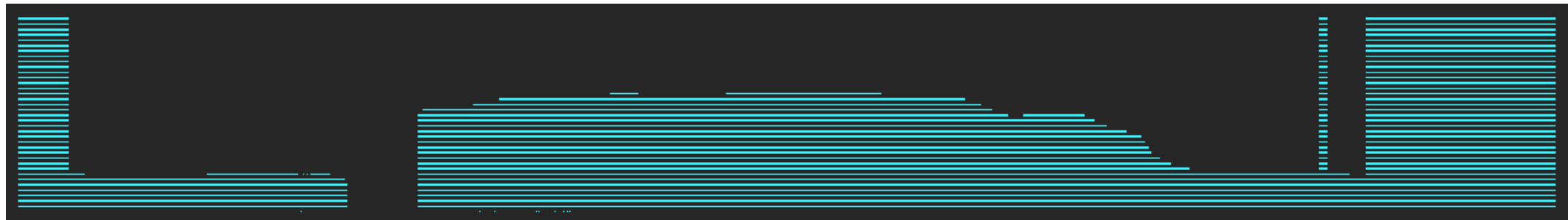
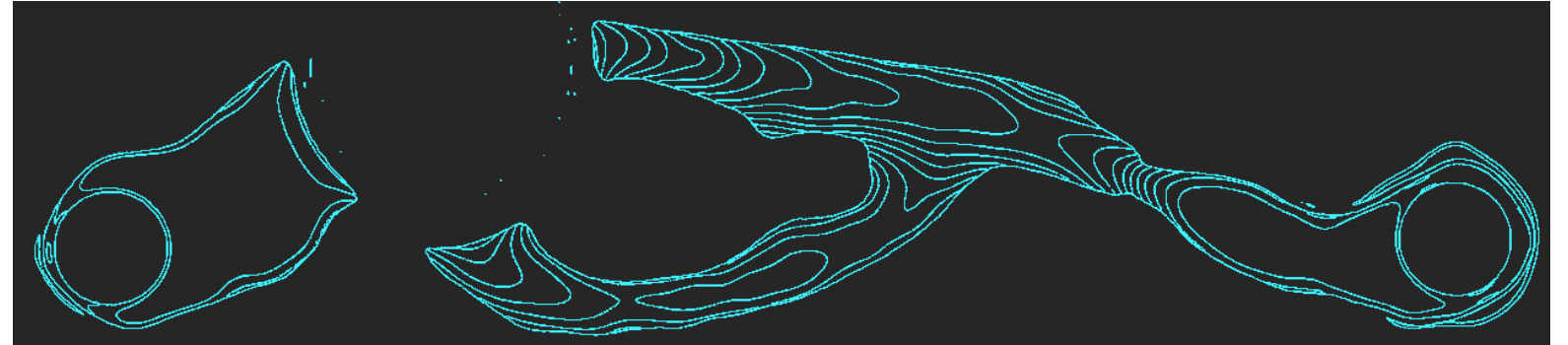
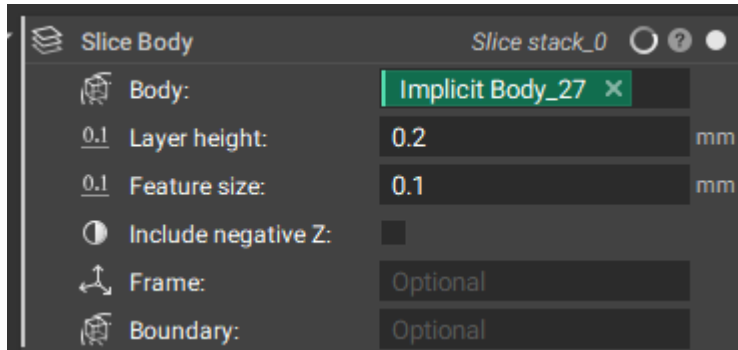

Merge Slicing Results

Add a **Merge Slice Stacks** block

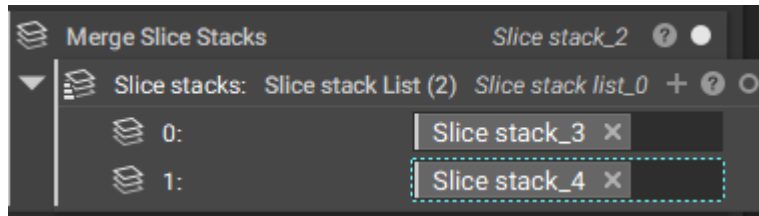

Export Merge Slicing

Add a **Export Slices to CLI** or **CLM** block

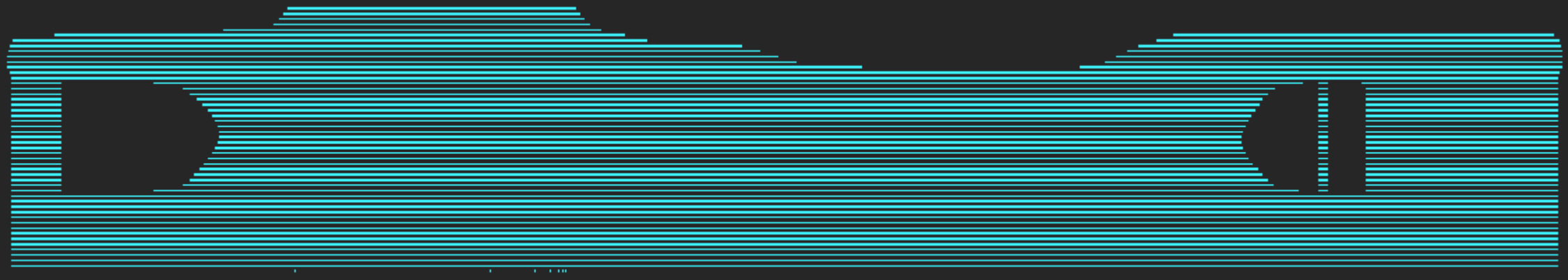
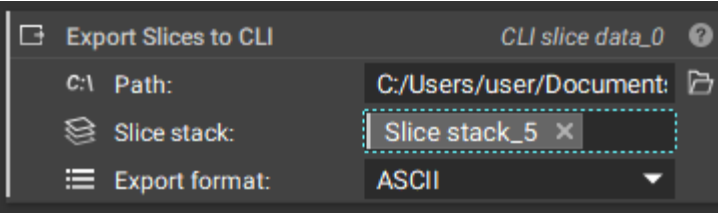

Export to .stl, .3MF, .obj

Convert the model to mesh e.g. Add a **Mesh from implicit model block**

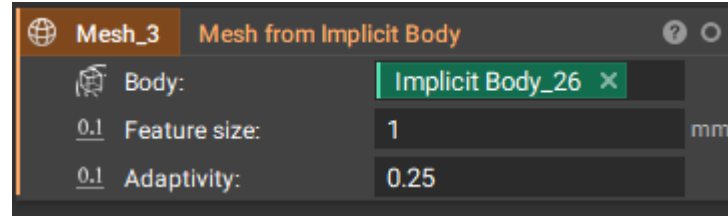

Then Add a **Mesh export block**

