

HD74LS76A

Dual J-K Flip-Flops (with Preset and Clear)

Features

- Ordering Information

Part Name	Package Type	Package Code (Previous Code)	Package Abbreviation	Taping Abbreviation (Quantity)
HD74LS76AP	DILP-16 pin	PRDP0016AE-B (DP-16FV)	P	—
HD74LS76ARPEL	SOP-16 pin(JEDEC)	PRSP0016DG-A (FP-16DNV)	RP	EL(2,500 pcs/reel)

Note: Please consult the sales office for the above package availability.

Pin Arrangement

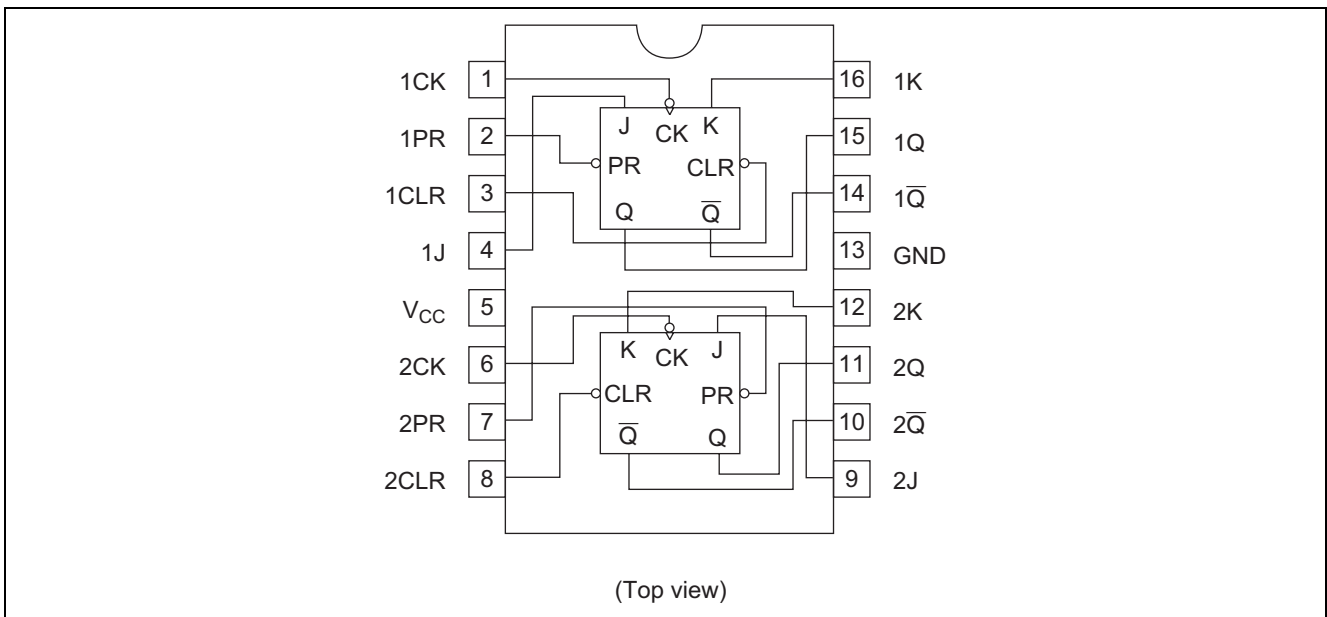

Function Table

Inputs					Outputs	
Preset	Clear	Clock	J	K	Q	\bar{Q}
L	H	X	X	X	H	L
H	L	X	X	X	L	H
L	L	X	X	X	H*	H*
H	H	↓	L	L	Q ₀	\bar{Q}_0
H	H	↓	H	L	H	L
H	H	↓	L	H	L	H
H	H	↓	H	H	Toggle	
H	H	H	X	X	Q ₀	\bar{Q}_0

H; high level, L; low level, X; irrelevant, ↓; transition from high to low level,

Q₀; level of Q before the indicated steady-state input conditions were established.

\bar{Q}_0 ; complement of \bar{Q}_0 or level of Q before the indicated steady-state input conditions were established.

Toggle; each output changes to the complement of its previous level on each active transition indicated by ↓.

* This configuration is nonstable; that is, it will not persist when preset and clear inputs return to their inactive (high) level.

Block Diagram (1/2)

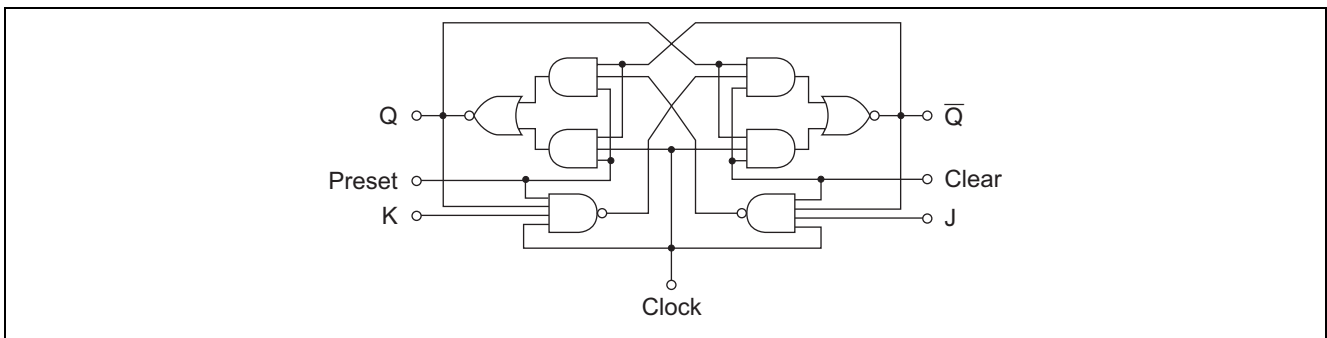

Absolute Maximum Ratings

Item	Symbol	Ratings	Unit
Supply voltage	V _{CC}	7	V
Input voltage	V _{IN}	7	V
Power dissipation	P _T	400	mW
Storage temperature	T _{stg}	-65 to +150	°C

Note: Voltage value, unless otherwise noted, are with respect to network ground terminal.

Recommended Operating Conditions

Item	Symbol	Min	Typ	Max	Unit
Supply voltage	V _{CC}	4.75	5.00	5.25	V
Output current	I _{OH}	—	—	-400	μA
	I _{OL}	—	—	8	mA
Operating temperature	T _{opr}	-20	25	75	°C
Clock frequency	f _{clock}	0	—	30	MHz
Pulse width	Clock High	t _w	20	—	ns
	Clear Preset Low	t _w	25	—	
Setup time	"H" Data	t _{su}	20↓	—	ns
	"L" Data	t _{su}	20↓	—	
Hold time	t _h	0↓	—	—	ns

Electrical Characteristics

(Ta = -20 to +75 °C)

Item	Symbol	min.	typ.*	max.	Unit	Condition	
Input voltage	V _{IH}	2.0	—	—	V		
	V _{IL}	—	—	0.8	V		
Output voltage	V _{OH}	2.7	—	—	V	V _{CC} = 4.75 V, V _{IH} = 2 V, V _{IL} = 0.8 V, I _{OH} = -400 μA	
	V _{OL}	—	—	0.5	V	V _{CC} = 4.75 V, V _{IH} = 2 V, V _{IL} = 0.8 V	
—		—	0.4				
Input current	J, K	—	—	20	μA	V _{CC} = 5.25 V, V _I = 2.7 V	
	Clear			60			
	Preset			60			
	Clock			80			
	J, K	—	—	-0.4	mA		V _{CC} = 5.25 V, V _I = 0.4 V
	Clear			-0.8			
	Preset			-0.8			
	Clock			-0.8			
	J, K	—	—	0.1	mA	V _{CC} = 5.25 V, V _I = 7 V	
	Clear			0.3			
	Preset			0.3			
	Clock			0.4			
Short-circuit output current	I _{OS}	-20	—	-100	mA		V _{CC} = 5.25 V
Supply current***	I _{CC}	—	4	6	mA		V _{CC} = 5.25 V
Input clamp voltage	V _{IK}	—	—	-1.5	V		V _{CC} = 4.75 V, I _{IN} = -18 mA

Notes: * V_{CC} = 5 V, Ta = 25°C

** I_{IL} should not be measured when preset and clear inputs are low at same time.

*** With all outputs open, I_{CC} is measured with the Q and Q̄ outputs high in turn. At the time of measurement, the clock input is grounded.

Switching Characteristics

(V_{CC} = 5 V, Ta = 25°C)

Item	Symbol	Inputs	Outputs	min.	typ.	max.	Unit	Condition
Maximum clock frequency	f _{max}			30	45		MHz	C _L = 15 pF, R _L = 2 kΩ
Propagation delay time	t _{PLH}	Clear	Q, Q̄	—	15	20	ns	
	t _{PHL}	Preset Clock		—	15	20	ns	

Timing Definition

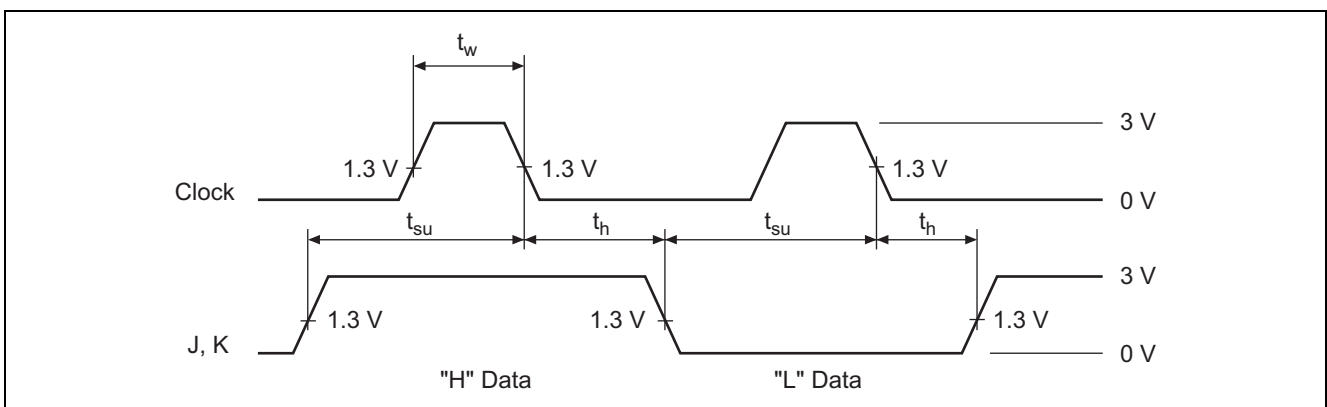

Testing Method

Test Circuit

1. f_{max} , t_{PLH} , t_{PHL} , (Clock \rightarrow Q, \bar{Q})

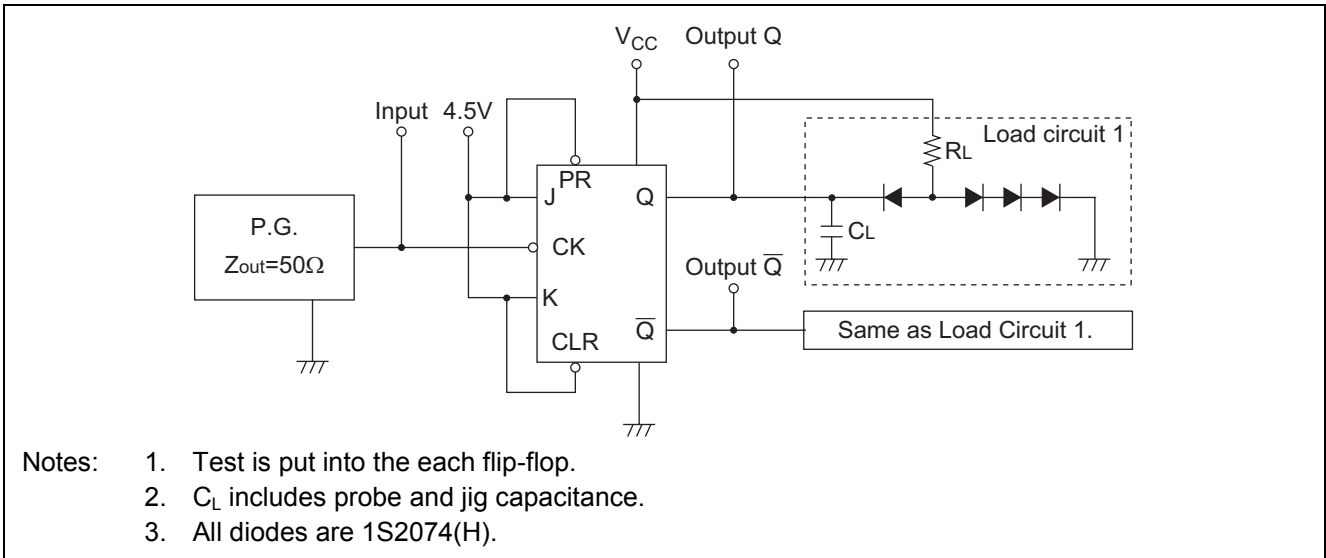

2. t_{PHL} , t_{PLH} (Clear, Preset \rightarrow Q, \bar{Q})

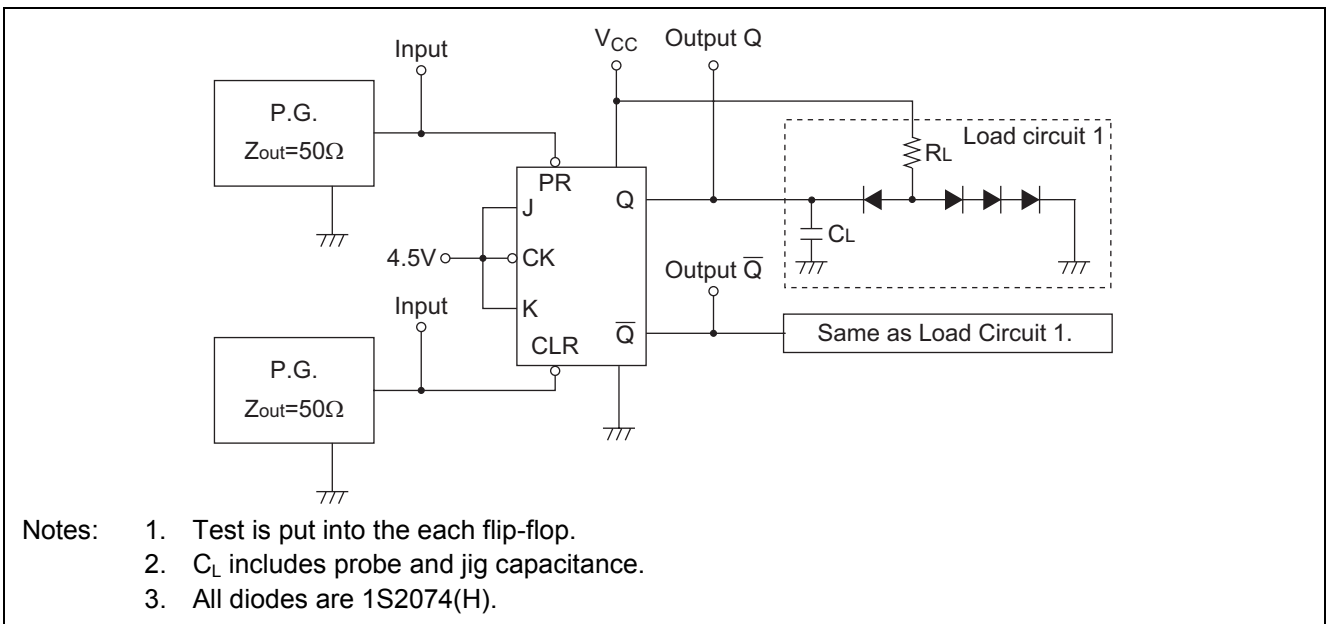

Waveforms 1

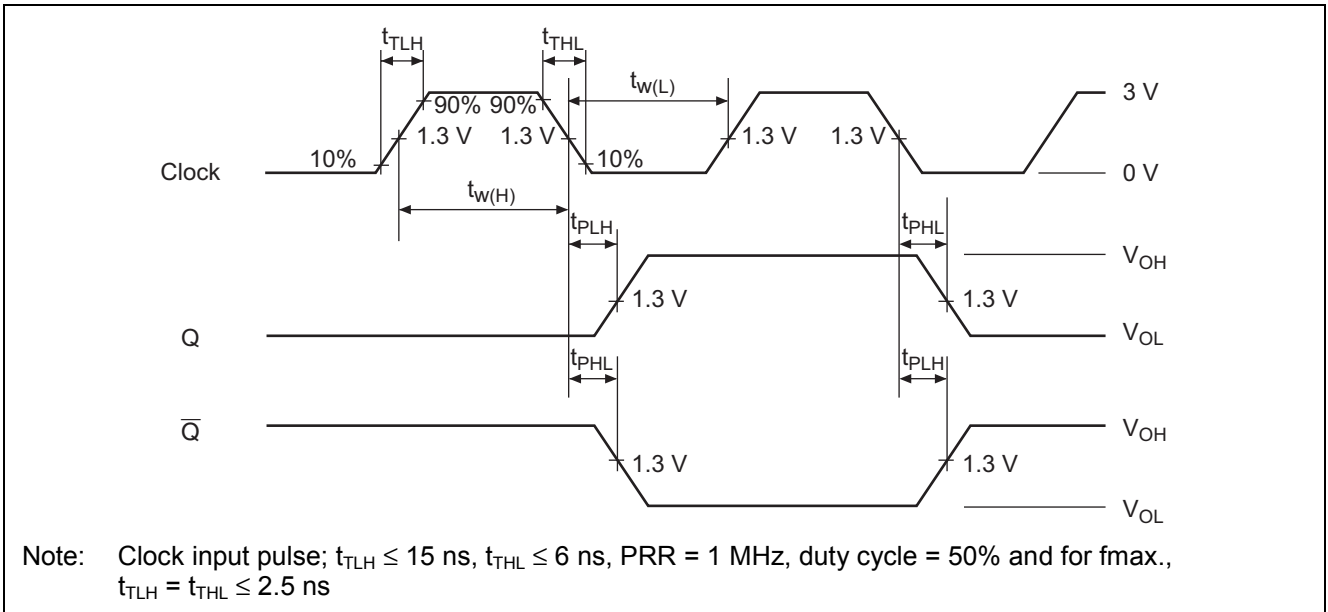

Waveforms 2

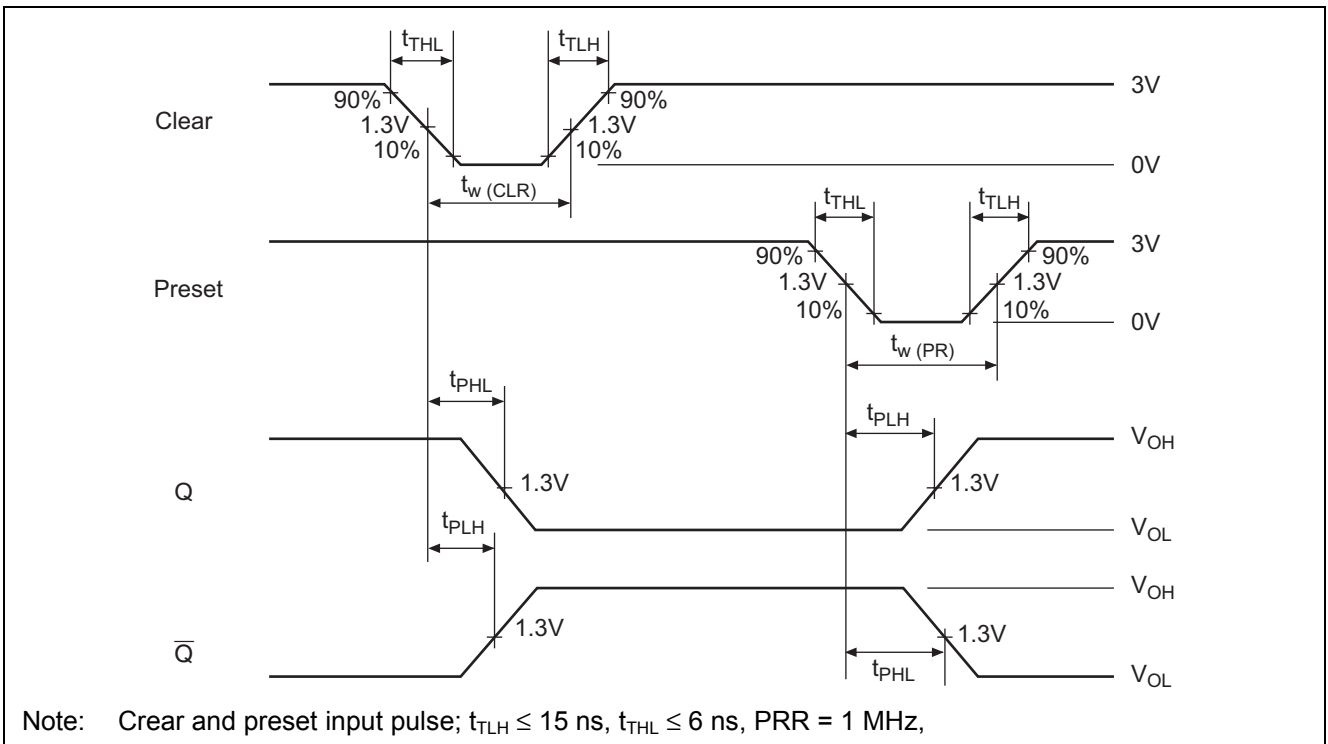

Package Dimensions

